

Tax Liability-Side Equivalence in Experimental Posted-Offer Markets

Rainald Borck,* Dirk Engelmann,* Wieland Müller,* and Hans-Theo Normann*†

In theory, the incidence of a tax should be independent of the side of the market on which it is levied. This principle of liability-side equivalence underlies virtually all theories of tax incidence. Policy discussions, however, tend to place great emphasis on the legal division of tax payments. We use computerized experimental posted-offer markets to test liability-side equivalence. We find that market outcomes are essentially the same when the tax is levied on sellers as when it is levied on buyers. Thus, we cannot reject liability-side equivalence.

1. Introduction

One of the central results of tax incidence theory is that “the incidence of the tax does not depend on which side of the market it is levied” (Kotlikoff and Summers 1987, p. 1046). This result—called liability-side equivalence (henceforth LSE)—holds for a variety of market structures under the assumption that prices are flexible and individuals maximize their material well being. In fact, this principle has been so widely accepted by economists that its empirical validity has rarely been tested.

This is rather surprising, given that the statutory incidence (the legal definition of tax liability) of taxes and other levies plays an important role in popular discussions. An article in *The Economist* on the Scandinavian countries argued that one reason for the large size of the welfare state was that “employers pay unusually heavy social-security contributions, while employees pay little—encouraging the impression that benefits cost nothing” (Cairncross 1994).

In Germany, the introduction of nursing care insurance was accompanied by heated debates on how contributions should be split between employers and employees. In fact, just before the system was introduced, the division of contributions was the central matter of conflict (Hinrichs 1995).¹ The weekly newspaper *Die Zeit* summarized the discussion in an article entitled “Useful Illusion” (Perina 1995). Proponents of scrapping the employer share of contribution argued mainly that, if employees had to bear the entire contribution, they would be more aware of the full costs of insurance and therefore possibly opt for lower spending levels. In addition, proponents argued that reducing the employer share would lower labor costs and therefore improve

* Humboldt-Universität zu Berlin, Spandauer Strasse 1, 10178 Berlin, Germany.

† Present address: Department of Economics, Royal Holloway, University of London, Egham, Surrey TW20 0EX, United Kingdom; E-mail hans.normann@rhul.ac.uk; corresponding author.

We thank Jörg Breitung, Tim Cason, Brit Großkopf, Georg Kirchsteiger, and Manfred Königstein, as well as participants of the ESA European Regional Meeting 1999, Jonathan Hamilton, and the anonymous referees for helpful comments and suggestions. Financial support from the TMR project ENDEAR of the European Commission is gratefully acknowledged.

Received June 2000; accepted May 2001.

¹ Note that both employees and employers strongly resisted being “burdened” with the entire contribution (Hinrichs 1995).

the competitive position of German firms. Representatives of unions argued on the contrary that an equal split of contributions would be fair and should therefore be incorporated.

The same concerns were reflected in another recent discussion in Germany. This discussion concerned the introduction of a fully funded pension system to supplement the current pay-as-you-go system. The government was planning to let employees pay the entire contribution. Commented one leading Social Democrat: “I was thunderstruck when I read this.”²

The division of contributions to social security systems also varies among countries, whereas economic theory would suggest that the choice should be dictated by minimization of administrative costs. Therefore, one would expect much more homogeneity. Similarly, minimization of administrative costs implies that formal incidence should probably fall on one side of the market only. This is, however, not the case in many countries.

LSE has important policy applications. An interesting example where tax incidence plays a role is the European Commission’s (Commission of the European Communities 2000) proposal for the taxation of e-commerce. For business-to-business (B2B) transactions, the tax liability would fall on the customer, while for business-to-consumer (B2C) transactions, the supplier would be legally liable for the tax. Whether or not this matters is an important question.³

All these controversies and policy issues seem to be based on the notion that statutory incidence matters for economic outcomes. The question is whether there could be a behavioral explanation why statutory incidence might matter. Kerschbamer and Kirchsteiger (2000) propose such an explanation. They claim that statutory incidence may play a role if agents are not fully rational. In particular, if individuals mistakenly base their decisions on gross instead of net earnings, legal incidence may affect the economic incidence of taxes. Kerschbamer and Kirchsteiger (2000, p. 721) argue that “it seems quite plausible that the legal obligation to pay a tax is regarded as a moral obligation to bear it (to a certain degree) also economically.” If this is the case, then statutory incidence may affect market outcomes.

In this article, we test LSE in a controlled laboratory experiment. Testing for LSE is of interest both because of the policy implication mentioned above and because it is a universal tenet of economic theory. Experimental markets provide a useful way to analyze the impact of taxes. Kachelmeier, Limberg, and Schadewald (1991) and Franciosi et al. (1995) analyze the effect of fairness on prices, investigating how switching from a profit tax to a sales tax affects prices under designs that differed with respect to whether or not sellers’ profits were disclosed. While Kachelmeier, Limberg, and Schadewald (1991) use posted-bid pricing, Franciosi et al. (1995) extend their study to posted-offer markets.⁴

Two experimental articles address the question whether statutory incidence matters for actual incidence. Kachelmeier, Limberg, and Schadewald (1994) examine consumption taxes in a complex double auction environment comprising both wholesale and retail markets. In particular, they study theoretically equivalent *ad valorem* taxes on consumers and on retailers (middlemen) and a value-added tax on producers and retailers. Their data tend to confirm LSE. Kerschbamer and Kirchsteiger (2000) let subjects play an ultimatum game (Güth, Schmittberger, and Schwarze 1982), where in one treatment a tax has to be paid by the proposer and in the

² *Der Tagesspiegel*, 8 June 2000, p. 14.

³ There are other important differences here. In particular, this pertains not to who pays the tax but where it is paid. B2B transactions are to be paid in the customer’s country—destination principle—while B2C transactions are taxed in the country of origin of the supplier—origin principle. This asymmetry may have important allocative consequences.

⁴ Quirmbach, Swenson, and Vines (1996) run experiments to test tax incidence theory based on the Harberger model. They do not study how legal incidence affects the effective incidence of taxes.

other by the responder.⁵ They find that the side on which the tax is levied bears a significantly higher burden of the tax. Taken together, these two studies provide conflicting evidence concerning the predictive power of LSE. Apparently, whether or not LSE holds depends crucially on the market institution underlying the experiments.

Given this conflicting evidence, additional research on LSE is warranted. Consider the market institutions of these articles. Double auctions, on the one hand, are known to converge quickly to the competitive equilibrium (for a survey, see Davis and Holt 1993, ch. 3). The use of a double-auction environment by Kachelmeier, Limberg, and Schadewald (1994) therefore probably gives LSE a better chance than it would have in other environments. On the other hand, myriads of experiments have shown that the subgame perfect equilibrium is almost never played in the ultimatum game. It is, therefore, not entirely clear what prediction is being tested in Kerschbamer and Kirchsteiger (2000). Since the equilibrium without taxes is not played by experimental subjects, it is hard to interpret any systematic difference between treatments as failure of LSE. We therefore think that experimental tests of tax incidence in a different trading institution might help improve the understanding of the empirical validity of LSE in general and the results in Kachelmeier, Limberg, and Schadewald (1994) and Kerschbamer and Kirchsteiger (2000) in particular.

Our test of LSE uses posted-offer markets (see Davis and Holt 1993, ch. 4), an institution that presents a compromise between the two trading institutions exemplified by double auctions and the ultimatum game.⁶ In posted-offer markets, “adjustment to equilibrium tends to be from above and either converges to equilibrium more slowly [than in double auctions] or does not converge at all” (Plott 1982, p. 1498). Such supracompetitive prices might enable sellers to bear a smaller share of the tax burden than theory predicts. For these reasons, testing tax liability equivalence in posted-offer markets might provide a stronger test of the theory than a test with double auctions. Compared with ultimatum bargaining experiments, outcomes in posted-offer markets match the equilibrium predictions quite well. In this sense, we give LSE a better shot than did Kerschbamer and Kirchsteiger (2000).

In essence, according to the studies mentioned above, we have two results for LSE, one (Kachelmeier, Limberg, and Schadewald 1994) that confirms it in a market institution that generally works well (in the sense of yielding predicted equilibrium outcomes) and one (Kerschbamer and Kirchsteiger 2000) that rejects it in a setting where experimental results are notoriously far away from the equilibrium prediction. Which market form is best suited to test LSE depends on the particular question at hand, but we would submit that, for many of the real-world markets where taxes play a role, posted-offer markets are a more representative trading institution than either double auctions or the ultimatum game.

We perform a test of tax liability-side equivalence in simple posted-offer markets involving buyers and sellers. In contrast with the *ad valorem* tax implemented by Kachelmeier, Limberg, and Schadewald (1994), we use unit taxes in two treatments where the only difference is who has to pay the tax. Unit taxes are arguably not representative for most taxes because (unlike value-added taxes or other *ad valorem* taxes) they are not a function of prices. However, there

⁵ In the ultimatum game, the first player (the proposer) offers a division of a pie of fixed size to the second player (the responder). The responder can accept the division, in which case it is implemented, or reject it, in which case both players earn nothing.

⁶ Strictly speaking, the ultimatum game is a posted-offer market with only one seller and one buyer who bargain on the sale of a single unit of a good. In addition to the economic frame of posted-offer markets (see Hoffman et al. 1994), multiple sellers and buyers distinguish our experiment from that of Kerschbamer and Kirchsteiger (2000).

are important unit taxes, for example, taxes on gasoline, cigarettes, and alcoholic beverages, to name a few. Moreover, given the growing attention to taxation of energy consumption, their relative share of the tax revenue may well be increasing. Our main reason for choosing unit taxes was to keep the design simple.⁷ When interpreting our results, it should be kept in mind that they may not generalize to *ad valorem* taxes, although the consistency of results between Kachelmeier, Limberg, and Schadewald (1994) and those reported here suggests that the form of tax may not be critical. That is, our experimental data do not reject the theoretical proposition that effective incidence is not affected by statutory incidence.

We proceed as follows. The next section presents the setup of the market used in the experiment and the experimental design. Section 3 presents results. The last section concludes with a discussion of the results.

2. Experimental Design and Procedures

Our experiment consists of 10 standard posted-offer markets. We also conducted two markets where subjects with the same cost and demand schedule negotiated via double auction (see section 3). For reasons mentioned above, the double auctions were conducted to check for robustness of the trading institution. In each market, three sellers and three buyers interacted. In most cases, two markets were conducted simultaneously, but subjects were informed that they interacted only within their group of six.

The experiment was conducted at Humboldt-Universität zu Berlin, Germany. The posted-offer markets were computerized. The programming of the experiments was implemented in Z-Tree, software developed by Fischbacher (1999). The total of 60 subjects were recruited from business and economics courses. None of them had previously participated in an experiment with posted-offer markets. Subjects were placed at isolated computer terminals. They were then given written instructions.⁸ These instructions were the same for both sellers and buyers, and subjects were not informed about the role they would play at that point. Subjects could then ask clarifying questions. Subjects were informed about the number of buyers and sellers and that each could buy or sell at most five units, but there was no revelation of costs or valuations of any of the other market participants.

We had two treatments, which differed only with respect to the side responsible for paying the tax. In one treatment, called BuyerTax, buyers paid the tax; in the other, called SellerTax, it was paid by the sellers. In total, 24 periods were played in each market, 12 without taxes followed by 12 periods with a tax. There were five markets for each of the two treatments. Collected tax revenue did not generate a public good. From the subjects' point of view, it simply disappeared. Subjects were informed before the experiment started that, after 12 periods, a change in the market would occur and that 12 more periods would follow. No indication was made at this stage that this change would be the introduction of a tax.

The cost and demand structure underlying our posted-offer markets is shown in Figure 1.

⁷ In contrast with *ad valorem* taxes, choosing a unit tax allows us to have the same tax rate in both treatments when leaving the ratio of tax burden to gross prices constant. Another notable aspect of *ad valorem* taxes is that the tax burden decreases, and thus efficiency increases, with decreasing prices (at least when tax revenue is wasted, as in our experiment). Although this should not in principle influence LSE, we wanted to avoid this problem since concerns for efficiency are an important motivation in many laboratory experiments.

⁸ The instructions as well as data on the individual markets are available from the authors upon request.

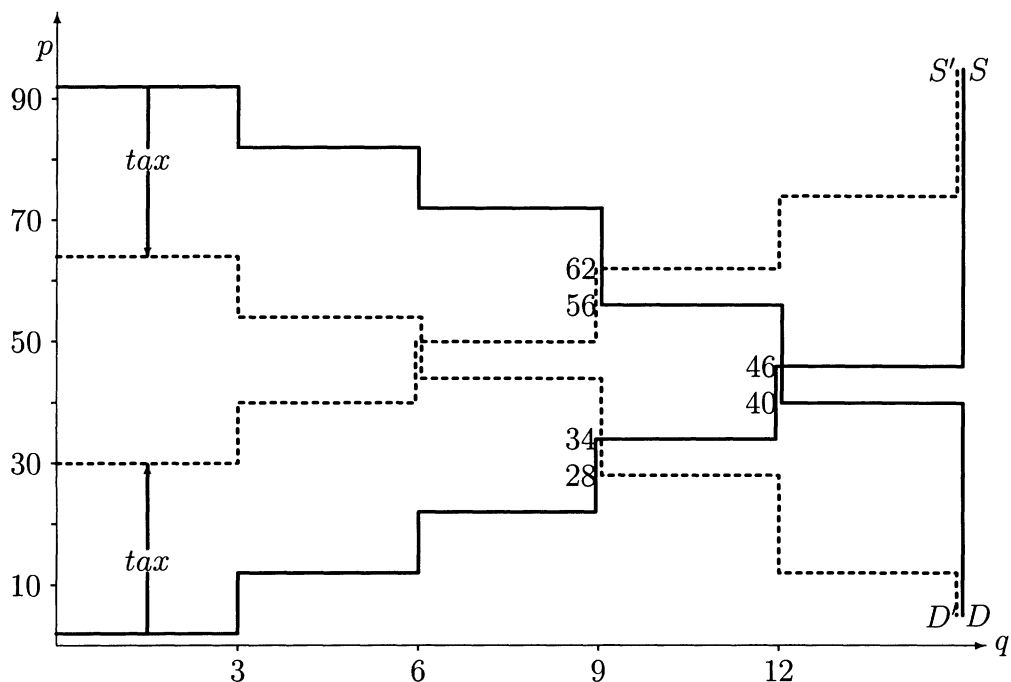

Figure 1. The Experimental Markets

Note that each step on the cost and demand function consists of three units, one for each seller and each buyer. This implies that, at the competitive price range, $40 \leq p \leq 46$, 12 units are sold when there is no tax. More specifically, each seller sells and each buyer purchases exactly four units.⁹ Payoffs at a competitive price of 43 are 102 Taler (the experimental currency unit) for sellers and 130 Taler for buyers. This asymmetry to the advantage of the buyers was introduced to offset an expected effect of the market power of sellers. Because subjects were unaware of the payoffs of the other subjects, this asymmetry could not cause a price increase due to equity considerations. (Note that, in Figure 1, the graphs are slightly offset to make the parts where they overlap more visible.)

Holt and Solis-Soberon (1992) argue that it is useful to derive Nash equilibrium prices in addition to the competitive price range. Sellers could post only integer prices. Under the standard assumption that demand will be split equally between the sellers if posted prices are equal (see, e.g., Holt and Solis-Soberon 1992), there are six symmetric pure-strategy Nash equilibria. Each equilibrium involves a price of the set $\{46, \dots, 51\}$ and five units offered by each seller. In these Nash equilibria, sellers will sell four units each but will sell less if they increase the price. Note, however, that, for prices up to 56, buyers will also buy four units each. Market efficiency is identical for the competitive equilibrium and the six Nash equilibria. The multiplicity of Nash equilibria results from the use of discrete prices (which are realistic in both laboratory and field markets). With a continuous action space, marginal undercutting would allow a fifth unit to be

⁹ We wanted to have a relatively large number of units being sold without a tax so that, after the introduction of the tax, the reduction of the number of units sold and the resulting reduction of payoffs is not too drastic. Low payoffs may frustrate subjects and induce nonsensical decisions (see Holt 1985).

sold at almost no loss on the other units, so there would be a unique Nash equilibrium in which all players post a price of 46 and offer five units.

Although it is standard, the assumption that demand will be split equally in case of a tie is restrictive and is made for convenience. It is indeed the case that, if demand is not split equally but randomly (which is the appropriate assumption if buyers are believed to decide randomly between offers with equal prices), there is an incentive to undercut the price due to the danger to sell less than four units. It is possible but tedious to show that there are no pure Nash equilibria in our game and that prices in a mixed equilibrium must lie above the competitive price range. Thus, the basic property of the above Nash equilibria—namely, that prices are above the competitive price range—still holds if the simplifying assumption is relaxed.

Furthermore, the predictive value of Nash equilibria is limited in the first place because the sellers do not know (and do not even know a possible range for) the buyers' demand function. So as a game between the sellers, the game is not completely specified and thus they cannot really play Nash equilibria. Any Nash equilibrium for a game between the sellers rests on the unwarranted assumption that sellers know the buyers' demand function (and that buyers maximize profits). Therefore, the Nash equilibria have a restricted predictive value and rather serve an illustrating purpose.

After the tax of 28 Taler per unit is introduced, the economic prediction changes to nine units sold at competitive prices, three for each participant, irrespective of whether the tax is levied on buyers or sellers. The revised competitive price range is 56–62 in gross prices and 28–34 in net prices. The Nash equilibria (again assuming equal split of demand in case of a tie) are for each seller to offer four units. Symmetric gross equilibrium prices are in the range {62, . . . , 66} and net prices are in the range {34, . . . , 38}. That is, there are five symmetric pure-strategy Nash equilibria, in which sellers sell three units each. Buyers will buy three units each for prices up to 72 or 44, respectively. Payoffs at a competitive price of 59 (or 31) are 57 Taler for sellers and 69 Taler for buyers.

Our markets followed the standard rules for computerized posted-offer markets (see Davis and Holt 1993, ch. 3). The only nonstandard feature is the introduction of the tax after the 12th period. At that point, the experimenter publicly announced that a tax of 28 Taler for each unit bought or sold would be imposed on one side of the market (sellers or buyers, depending on the treatment). Then 12 more periods were played under standard rules except that at all stages where information was given concerning the costs or values of units sold, the tax was indicated explicitly (for buyers or sellers, depending on the treatment). Also, the tax was included in the computation and feedback of profits per individual unit.

At the end of the 24 periods, a questionnaire was filled in by the subjects. They were asked for some biographical data and how they had made their decisions. Finally, they were informed about their total payment in DM, which was paid immediately after the end of the experiment. The exchange rate was 1 DM for 60 Taler. On average, subjects earned DM 31.00, or approximately U.S. \$14. The average duration of a session was 75 minutes.

3. Experimental Results

Figure 2 and Table 1 summarize the experimental results. Figure 2 shows graphically the evolution of the mean of those prices that resulted in contracts along with the number of units

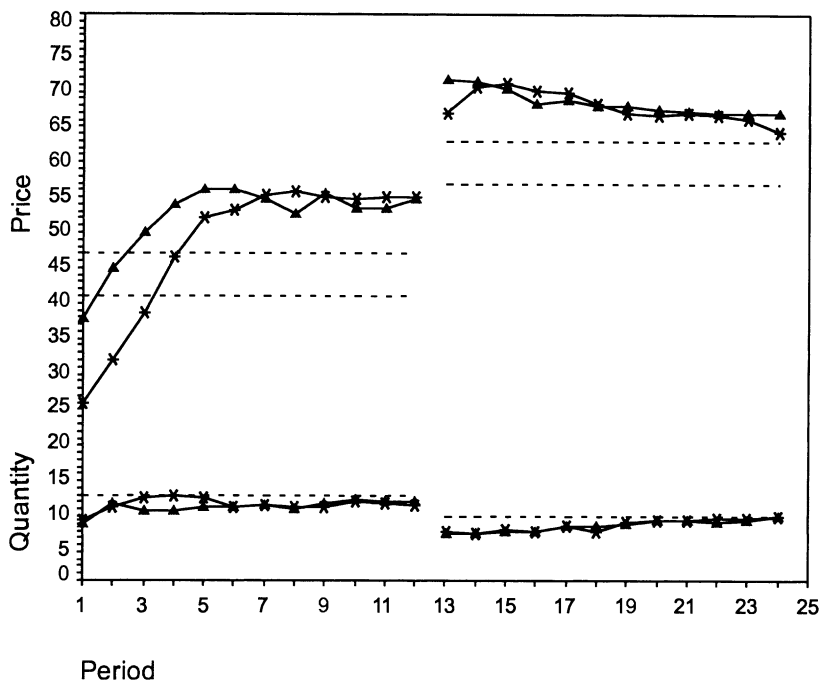

Figure 2. Summary of Experimental Results (★, SellerTax; ▲, BuyerTax)

sold.¹⁰ Stars (★) and solid triangles (▲) are used to indicate these numbers for the treatments SellerTax and BuyerTax, respectively. Note that prices for periods 13–24 of the BuyerTax treatment are reported after adding the unit tax, that is, the gross prices paid by buyers. In Figure 2, the ranges of competitive price predictions and competitive quantity predictions are indicated by dotted horizontal lines extending across periods 1–12 (first phase) and periods 13–24 (second phase). Although the first phase was identical in both treatments, Figure 2 and Table 1 report the corresponding results separately for the two treatments. This was done to make visible the effect of the imposition of the tax on first-period behavior in the second phase in comparison with last-period behavior in the first phase of the experiment.

Inspecting Figure 2 and Table 1, we make a number of observations. First, in both treatments, average prices in period 1 are below the lower end of the competitive price range (40), and in periods 1–6, average prices in treatment BuyerTax are higher than in treatment SellerTax. (The latter, however, seems entirely due to the fact that, in treatment BuyerTax, sellers [by chance] start in period 1 with higher prices on average.) Second, crossing the range of competitive prices, mean prices in both treatments quickly jump upward and stabilize at a common level of about 52–53, which is distinctly above the upper end of the competitive price range (46). Third, in periods 7–12, there is no trend whatsoever in the evolution of the mean prices in the two treatments. By the last period of the first (pretax) phase (period 12), the average price was virtually the same in both treatments, namely 53.9 (SellerTax) versus 53.7 (BuyerTax). Finally, the level of units sold during the pretax phase of the experiment is stable over the rounds. The average number of units is 10.45, slightly below the competitive quantity prediction

¹⁰ As can be seen in Table 1, the average prices per period do not differ much whether or not the prices are weighted with the number of units sold. The unweighted average prices are shown here.

Table 1. Summary of Experimental Results

Period	SellerTax						BuyerTax							
	Price	Min	Max	Var	Weighted Price	Quantity	Efficiency (in %)	Price	Min	Max	Var	Weighted Price	Quantity	Efficiency (in %)
1	24.8	6	40	104.3	26.6	8.4	72.5	36.7	20	55	129.2	38.6	8.0	65.4
2	31.0	10	45	79.4	33.3	10.4	84.5	43.9	30	80	182.6	43.8	10.8	90.7
3	37.7	28	47	37.4	38.8	11.6	93.7	48.9	34	65	77.9	49.6	9.8	85.9
4	45.5	38	56	34.4	45.6	11.8	96.5	53.1	40	70	64.7	52.2	9.8	83.3
5	51.1	42	60	32.4	50.6	11.6	92.9	55.0	40	66	52.8	54.5	10.2	87.8
6	52.2	43	60	26.7	52.2	10.4	86.8	55.1	47	70	45.8	53.4	10.2	86.9
7	54.4	47	60	11.8	54.4	10.6	92.0	53.8	35	65	57.7	53.3	10.6	88.9
8	54.9	52	58	4.7	54.5	10.4	90.0	51.8	15	66	139.4	53.7	10.0	86.1
9	54.2	50	60	8.3	53.8	10.2	86.2	54.5	47	66	25.4	53.9	10.8	92.2
10	53.9	46	61	10.8	53.4	11.0	93.4	52.6	46	60	18.0	52.5	11.4	93.1
11	53.9	47	62	16.6	53.2	10.8	91.5	52.3	46	61	17.8	52.1	11.2	94.0
12	53.9	48	62	18.6	53.2	10.6	88.0	53.7	48	65	28.8	52.3	11.0	90.1
Mean	47.3	38.1	55.9	32.1	47.5	10.6	89.0	50.9	37.3	65.8	70.0	50.8	10.3	87.0
13	65.9	51	82	139.7	65.9	7.0	77.5	70.8	54	85	96.3	69.0	6.6	75.3
14	69.6	60	80	45.3	69.8	6.6	70.0	70.6	62	77	27.8	70.1	6.6	66.7
15	70.1	60	80	33.2	69.7	7.2	79.3	69.4	63	76	22.2	69.0	6.8	74.7
16	69.1	62	75	24.1	69.0	7.0	78.1	67.2	62	74	18.6	67.5	7.0	74.3
17	69.0	62	74	17.7	68.6	7.6	86.1	67.8	61	74	19.6	67.0	7.8	83.3
18	67.3	62	73	17.0	67.4	7.0	74.5	67.1	62	74	21.0	66.3	7.6	84.6
19	66.1	55	73	31.9	66.2	8.2	87.2	67.0	61	73	15.1	66.5	8.0	85.6
20	65.8	60	71	12.7	65.9	8.6	89.4	66.5	60	71	14.3	66.4	8.6	90.0
21	66.1	61	72	10.6	65.8	8.6	93.4	66.2	59	70	13.5	66.0	8.6	92.2
22	65.6	62	70	7.5	65.6	8.8	92.3	66.1	59	70	14.8	65.9	8.2	89.0
23	65.1	61	70	8.0	65.0	8.8	93.4	66.0	59	70	13.1	66.0	8.6	91.2
24	63.4	60	70	8.6	63.8	9.0	94.6	66.0	60	70	10.6	66.0	9.0	92.8
Mean	66.9	59.7	74.2	29.7	66.9	7.9	84.7	67.6	60.2	73.7	23.9	67.1	7.8	83.3

of 12 units. This is due to the fact that prices occasionally exceed 56 so that demand is less than 12 units.

In the second phase of the experiment, sellers or buyers had to pay the tax of 28 Talers per unit. From Figure 2 and Table 1, we first observe that the average price in period 13 (the first posttax period) is 65.9 (SellerTax) and 70.8 (BuyerTax). In both treatments, this price is above the upper end of the competitive price range (62). This is true for all periods of the second phase. Second, in both treatments, there is an overall downward trend in the evolution of the mean price in the second phase of the experiment. Third, the overall downward trend in mean prices is accompanied by an upward trend in the evolution of the average number of units sold. However, whereas mean prices in both treatments are still supracompetitive in the last period, the number of units sold is exactly nine in the last period in all of the 10 markets, as predicted by the competitive equilibrium.

The prices above the competitive price range that consistently occur after the first four periods are mostly within the range of Nash-equilibrium prices. Although sellers are not exactly playing Nash equilibria in specific periods (as outlined above, they lack sufficient information to do so), the prices reflect that they may have understood the basic property of these equilibria. In some instances, offers with prices above the competitive range are for fewer units than are profitable. This may be attributed to attempts to collude.

We now turn to the main question of this study: Does it make a difference on which side of the market the tax is levied? In light of our experimental results, the answer to this question is no. There are hardly any differences in average prices (across all periods of the second phase) that resulted in contracts (66.9 in treatment SellerTax vs. 67.6 in treatment BuyerTax) and numbers of units sold (7.9 vs. 7.8; see the last line in Table 1).

To test for significance of the difference in transaction prices, we estimate a random-effects panel data model using the tax liability side as a dummy variable. This procedure is chosen in order to take the serial dependence of the data within one market into account. Letting p_{it} be a transaction price in market i and period t , our estimation equation is $p_{it} = \beta_0 + \beta_1 \text{SIDE} + v_i + \epsilon_{it}$. The dummy variable *SIDE* is equal to zero in treatment SellerTax and one in treatment BuyerTax. v_i is the market-specific residual, while ϵ_{it} is the usual residual with mean zero and is uncorrelated with *SIDE* and v_i .

Considering accepted contracts of the last six periods (19–24) of all markets (mean SellerTax: 65.3; mean BuyerTax: 66.3), we cannot reject the null hypothesis of no influence of the liability side ($\hat{\beta}_1 = 0.83$, $p = 0.709$).¹¹ Furthermore, the minimum and maximum prices differ only marginally between the two treatments in the last five periods, though the variance of prices is slightly higher in treatment BuyerTax. The prices of accepted contracts differ in the first period after the introduction of the tax (65.9, SellerTax; 70.8, BuyerTax), but this difference is not significant either ($\hat{\beta}_1 = 4.92$, $p = 0.275$).¹² The increase in prices through the introduction of the tax (12.0, SellerTax; 17.1, BuyerTax) is close to the predicted increase of 16. Furthermore, the difference between the two treatments disappears almost completely in the next period.

Efficiency (total surplus expressed as a percentage of the surplus in competitive equilib-

¹¹ If we include more than the last six periods, the estimate for β_1 gets even smaller and p increases. If we ignore the possible dependence and consider all prices that resulted in contracts in periods 19–24 as independent observations, we obtain a level of significance of $p = 0.09$. However, this difference is almost entirely driven by the last period: For periods 19–23, we obtain $p = 0.319$.

¹² Ninety-five percent confidence intervals for the coefficient of the treatment dummy are as follows: periods 19–24, [−3.53, 5.20]; period 24, [−1.65, 6.15]; period 13, [−3.92, 13.77].

rium) in the periods with tax is nearly equal in both treatments (SellerTax: 84.7; BuyerTax: 83.3). The difference is even smaller than the corresponding difference for the periods without tax (89.0 vs. 87.0), indicating that it is more likely a chance difference than a treatment effect.

On average, sellers earned DM 34.13 and buyers earned DM 27.88. In the periods with taxes, the relative earnings of sellers and buyers are roughly equal in both treatments (DM 12.71 to DM 8.62 in treatment SellerTax and DM 12.61 to DM 8.39 in treatment BuyerTax). Hence, the allocation of social wealth is not influenced by statutory incidence.

We also conducted two double-auction markets to check for LSE in this very competitive environment. Consistent with Kachelmeier, Limberg, and Schadewald (1994), there was no treatment effect here either. Both with and without tax, prices in treatment SellerTax are close to the upper end of the competitive price range, whereas in treatment BuyerTax, prices are slightly below the lower end of the competitive price range. The difference between prices in both treatments after introducing the tax is of the same magnitude as it is in the last two periods without tax. Note that this difference is opposite to what would be expected if tax liability side mattered, namely higher prices in treatment BuyerTax.

4. Conclusion

This study asks whether the incidence of a tax depends on which side of the market is formally liable to pay it. Contrary to Kerschbamer and Kirchsteiger (2000) but in line with the double-auction results of Kachelmeier, Limberg, and Schadewald (1994), we do not find a significant influence on the total price plus tax outlay of whether buyers or sellers are responsible for remitting the tax. Therefore, we conclude that, in posted-offer markets, the legal distinction about which side of the market has to pay a tax has little influence on market outcomes.

Together with the results of Kachelmeier, Limberg, and Schadewald (1994) and Kerschbamer and Kirchsteiger (2000), our results suggest that whether or not LSE holds depends on the market institution chosen. In a way, a test of LSE is a joint test of the market institution and LSE. Taking LSE as given, if a market institution gave the predicted outcome only with a zero tax, confidence in such a market institution would be weakened.¹³ Research on double-auctions and posted-offer markets suggests that these institutions perform consistently with the theory both with and without the tax. By contrast, data from ultimatum game experiments reject the theory with a zero tax as well as with a positive tax.

Kerschbamer and Kirchsteiger (2000) draw some policy conclusions from their experiments. In particular, they argue that statutory tax incidence may affect the performance of markets where social norms can affect the outcome. For instance, if the characteristics of a good are not completely specified before trade takes place, social norms may prevent market clearing. Therefore, LSE may fail. The ultimatum game is just such an institution where market clearing may be hindered by social norms. Kerschbamer and Kirchsteiger (2000) cite labor markets as an example where social norms matter and hence statutory incidence may have real effects. We have used posted-offer markets as an example of a market that functions reasonably well but not perfectly and found that incidence theory is confirmed. To a large extent, retail markets resemble posted-offer markets. Our experiment therefore offers a forum that compares to many field markets, suggesting that in many real-world settings LSE can be expected to hold.

¹³ This interpretation was suggested to us by Jonathan Hamilton.

From a methodological perspective, we can think of a continuum of market forms in which taxes can be implemented, ranging from those that converge very quickly, such as the double auctions studied by Kachelmeier, Limberg, and Schadewald (1994), to those that in general do not converge, like the ultimatum game setting used by Kerschbamer and Kirchsteiger (2000). Somewhere along this continuum might be a line that separates those markets where statutory incidence matters from those where it does not. Research can help us refine where exactly this line can be drawn.

In a recent article on fiscal illusion, Tyran and Sausgruber (2000) show that experimental subjects systematically misperceive the tax burden, leading to inefficient democratic decisions. Similar misperceptions might underlie the political discussions so that outcomes might be inefficient, not because LSE does not hold but because it is not acknowledged. It is thus important both to test whether LSE holds in relevant markets and, if it does, to communicate this result.

References

- Cairncross, Frances. 1994. Womb to tomb—The road to debt is paved with good intentions. *The Economist*, 5 November.
- Commission of the European Communities. 2000. Proposal for a COUNCIL DIRECTIVE amending Directive 77/388/EEC as regards the value added tax arrangements applicable to certain services supplied by electronic means. COM(2000) 349, Brussels.
- Davis, Douglas D., and Charles A. Holt. 1993. *Experimental economics*. Princeton, NJ: Princeton University Press.
- Fischbacher, Urs. 1999. Z-Tree: Zurich toolbox for readymade economic experiments. Working Paper No. 21, Institute for Empirical Research in Economics, University of Zurich.
- Franciosi, Robert, Praveen Kujal, Roland Michelitsch, Vernon Smith, and Gang Deng. 1995. Fairness: Effect on temporary and equilibrium prices in posted-offer markets. *Economic Journal* 105:938–50.
- Güth, Werner, Reiner Schmittberger, and Bernd Schwarze. 1982. An experimental analysis of ultimatum bargaining. *Journal of Economic Behavior and Organization* 3:367–88.
- Hinrichs, Karl. 1995. Die soziale Pflegeversicherung—eine institutionelle Innovation in der deutschen Sozialpolitik. *Staatswissenschaften und Staatspraxis* 6:227–59.
- Hoffman, Elizabeth, Kevin McCabe, Keith Shachat, and Vernon Smith. 1994. Preferences, property rights, and anonymity in bargaining experiments. *Games and Economic Behavior* 7:346–80.
- Holt, Charles A. 1985. An experimental test of the consistent-conjecture hypothesis. *American Economic Review* 75: 314–25.
- Holt, Charles A., and Fernando Solis-Soberon. 1992. The calculation of equilibrium mixed strategies in posted-offer auctions. In *Research in experimental economics 5*, edited by R. Mark Isaac. Greenwich, CT: JAI Press, pp. 189–228.
- Kachelmeier, Steven J., Stephen T. Limberg, and Michael S. Schadewald. 1991. A laboratory market examination of the consumer price response to information about producers' costs and profits. *Accounting Review* 66:694–717.
- Kachelmeier, Steven J., Stephen T. Limberg, and Michael S. Schadewald. 1994. Experimental evidence of market reactions to new consumption taxes. *Contemporary Accounting Research* 10:505–45.
- Kerschbamer, Rudolf, and Georg Kirchsteiger. 2000. Theoretically robust but empirically invalid? An experimental investigation into tax equivalence. *Economic Theory* 16:719–34.
- Kotlikoff, Lawrence J., and Lawrence H. Summers. 1987. Tax incidence. In *Handbook of public economics*, edited by Alan J. Auerbach and Martin Feldstein. Amsterdam: Elsevier, pp. 1043–92.
- Perina, Udo. 1995. Nützliche illusion. *Die Zeit*, 2 June, p. 27.
- Plott, Charles R. 1982. Industrial organization theory and experimental economics. *Journal of Economic Literature* 20: 1485–527.
- Quirnbach, Herman C., Charles W. Swenson, and Cynthia C. Vines. 1996. An experimental examination of general equilibrium tax incidence. *Journal of Public Economics* 61:337–58.
- Tyran, Jean-Robert, and Rupert Sausgruber. 2000. On fiscal illusion. Unpublished paper, University of St. Gallen.