

Local existence of a solution of a semi-linear wave equation in a neighborhood of initial characteristic hypersurfaces

Existence locale d'une solution d'équation d'onde semi-linéaire dans un voisinage des hypersurfaces caractéristiques initiales

Aurore Cabet

Laboratoire de Mathématiques et Physique théorique

Université de Tours

Parc de Grandmont, 37200 Tours, France.

aurore.cabet@etu.univ-tours.fr

September 2002

Abstract

In this paper we are concerned with a semilinear wave equation with initial data given on two transversely intersecting null hypersurfaces in the Minkowski space \mathbb{R}^{n+1} . We prove existence and uniqueness of a solution in a (one-sided future directed) neighborhood of the initial data null hypersurfaces.

Résumé

Dans cet article, nous nous plaçons dans l'espace de Minkowski \mathbb{R}^{n+1} et nous nous intéressons à une équation d'onde semi-linéaire avec données initiales sur des hypersurfaces caractéristiques. Nous prouvons l'existence et l'unicité d'une solution dans un voisinage dirigé vers le futur d'un côté de ces hypersurfaces.

1 Introduction

The problem we are interested in here is about a semilinear wave equation with data given on two transversely intersecting null hypersurfaces. Many problems with characteristic initial values have been studied in the last forty years. H. Friedrich [4] has written a few papers about characteristic initial value problem in the context of Einstein's vacuum

field equations (his work consists essentially in showing the way to apply the results of existence and uniqueness of solutions of wave equation with characteristic initial value). R. Courant and D. Hilbert [3] have shown the uniqueness of a solution of wave equation with data prescribed on a characteristic half-cone. Other works treat the Cauchy problem for quasi-linear equation with data on a characteristic conoid as F. Cagnac [1], F. Cagnac and M. Dossa [2]. In this article the initial characteristic hypersurfaces are N_+, N_- defined in the Minkowsky space \mathbb{R}^{n+1} by

$$\begin{aligned} N_+ &= \{t + x^1 = 0, t \geq 0, (x^2, \dots, x^n) \in \mathbb{R}^{n-1}\} \\ N_- &= \{t - x^1 = 0, t \geq 0, (x^2, \dots, x^n) \in \mathbb{R}^{n-1}\}. \end{aligned}$$

We know by standard results that there exists a global solution in the linear case. But in the case of a nonlinear hyperbolic equation, the published proofs give an existence (and uniqueness) of solutions in a neighborhood of the intersection of the null hypersurfaces, namely neighborhood with a finite time, as it is done in H. Müller zum Hagen and H.-J. Seifert [5] or A. D. Rendall [6].

In this paper we propose to demonstrate the existence and uniqueness of solutions in a one-sided neighborhood of both null hypersurfaces and not only of their intersection. More precisely, we consider in \mathbb{R}^{n+1} the problem

$$\begin{cases} \square\varphi(x, t) = F(\varphi(x, t), x, t) \\ \varphi|_{N_+} = \varphi_+ \\ \varphi|_{N_-} = \varphi_- \end{cases} \quad (1.1)$$

$$\text{where } \square = -\frac{\partial^2}{\partial t^2} + \Delta_x$$

and φ can be vector-valued .

We show, under certain conditions, that, for any positive real R , there exists positive reals R' and R'' such that there exists a unique C^2 solution in the domain $\mathcal{V}_R := \{0 \leq t - x^1 \leq R, 0 \leq t + x^1 \leq R', (x^2, \dots, x^n) \in \mathbb{R}^{n-1}\} \cup \{0 \leq t + x^1 \leq R, 0 \leq t - x^1 \leq R'', (x^2, \dots, x^n) \in \mathbb{R}^{n-1}\}$, then $\bigcup_R \mathcal{V}_R$ gives a one-sided neighborhood of the initial data hypersurfaces. We can visualize a part of this neighborhood by the following figure:

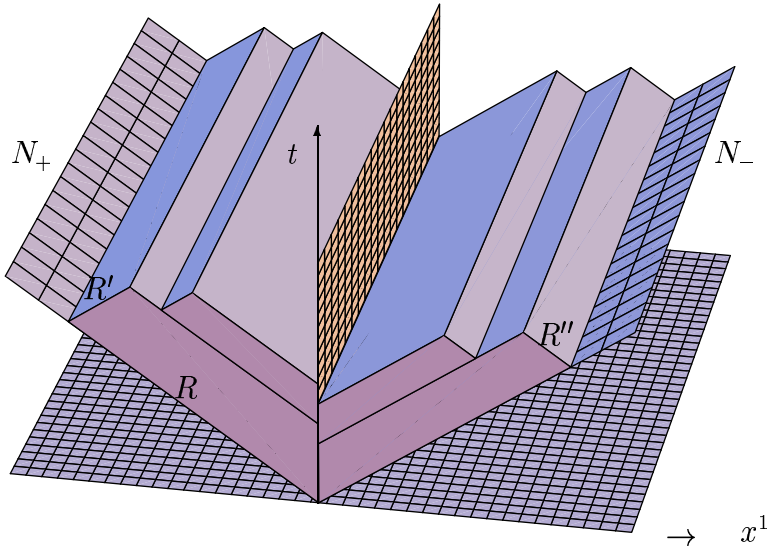

The proof is based on the Galerkin method with estimates of energy in some special Sobolev spaces. The mathematics tools used in this article are very classical, but the originality here is to apply a standard method by considering a isotropic direction as the time direction. Moreover the implementation of the different parts of the proof are not so trivial.

The structure of this article is organised as follows.

We start in section 2 by a short presentation and results about the spaces in which we will work. In the third section, we give the assumptions on the functions $F, \tilde{\varphi}_+, \tilde{\varphi}_-$ and we transform the problem to obtain an equation more convenient with a new function $(\tilde{\varphi}, u, v, y) \mapsto \tilde{H}(\tilde{\varphi}, u, v, y)$ where $u = (t - x^1)/2$, $v = (t + x^1)/2$, $y = (x^2, \dots, x^n)$ and \tilde{H} vanishes at $(0, u, 0, y)$. In section 4, we construct a spectral approximation of a solution of the precedent equation. Then we estimate in the fifth section the energy of these solutions in the spaces introduced at the beginning. We deduce of this in section 6 the existence of a solution $\tilde{\varphi}$ and we discuss its regularity. After that in section 7 we come back to the first equation and discuss also the regularity and uniqueness of the solution of the problem (1.1), to prove the uniqueness we use a classical tool namely the energy-momentum tensor. In section 8, we resume the results obtained in the simpler case of dimension $1 + 1$ where we can work in Sobolev spaces H^k .

2 Spaces $\mathcal{H}_{m,k}$

Let R be a strictly positive real, and \mathbb{T}^{n-1} a torus of length T in each direction. We will work in the spaces $\mathcal{H}_{m,k}$ where

$$\mathcal{H}_{m,k}([0; 2R] \times \mathbb{T}^{n-1}) = \left\{ \varphi \in L^2([0; 2R] \times \mathbb{T}^{n-1}); \right. \\ \left. \sum_{\substack{0 \leq a \leq k \\ 0 \leq |\nu| \leq m}} \int_0^{2R} \int_{\mathbb{T}^{n-1}} \left| \frac{\partial^a}{\partial v^a} \frac{\partial^{\nu_1}}{\partial y_1^{\nu_1}} \cdots \frac{\partial^{\nu_{n-1}}}{\partial y_{n-1}^{\nu_{n-1}}} \varphi \right|^2 dv d^{n-1}y < \infty \right\}$$

with derivatives of φ understood in the distribution sense. $\mathcal{H}_{m,k}$ is a Hilbert space hence it is reflexive.

We take a orthonormal basis of $L^2([0; 2R] \times \mathbb{T}^{n-1})$. So we set

$$\Psi_\alpha(v, y) = (2R)^{-\frac{1}{2}} T^{-\frac{n-1}{2}} e^{i(\alpha_0 v \frac{\pi}{R} + \bar{\alpha} \cdot y \frac{2\pi}{T})} \quad \text{with} \quad \alpha = (\alpha_0, \bar{\alpha}) \in \mathbb{Z}^n \\ \langle \Psi_\alpha, f \rangle = (2R)^{-\frac{1}{2}} T^{-\frac{n-1}{2}} \int_0^{2R} \int_{\mathbb{T}^{n-1}} e^{-i(\alpha_0 w \frac{\pi}{R} + \bar{\alpha} \cdot z \frac{2\pi}{T})} f(w, z) dw d^{n-1}z .$$

We know that $f = \sum_{\alpha \in \mathbb{Z}^n} \langle \Psi_\alpha, f \rangle \Psi_\alpha$ and we have

$$\| f \|_{\mathcal{H}_{m,k}}^2 = \sum_{\substack{0 \leq a \leq k \\ 0 \leq |\nu| \leq m}} \| D_v^a D_y^\nu f \|_{L^2([0; 2R] \times \mathbb{T}^{n-1})}^2 .$$

The proofs of the following results are similar as in the classical Sobolev spaces $W^{s,p}$ and can be found in Appendix A.

Lemma 2.1 *We have the equivalence*

$$\| f \|_{\mathcal{H}_{m,k}} \sim \left(\sum_{\alpha \in \mathbb{Z}^n} |\langle \Psi_\alpha, f \rangle|^2 (1 + |\alpha_0|)^{2k} (1 + |\bar{\alpha}|)^{2m} \right)^{\frac{1}{2}} .$$

Lemma 2.2 *Let l a positive integer.*

$$\text{If } \begin{cases} m > \frac{n-1}{2} + l \\ k > \frac{1}{2} + l \end{cases} \quad \text{then} \quad \mathcal{H}_{m,k}([0; 2R] \times \mathbb{T}^{n-1}) \subset C^l([0; 2R] \times \mathbb{T}^{n-1}) .$$

Lemma 2.3 *If $k < k'$ then $\mathcal{H}_{m,k'} \hookrightarrow \mathcal{H}_{m,k}$ with compact embedding.*

Similarly, if $m < m'$ then $\mathcal{H}_{m',k} \hookrightarrow \mathcal{H}_{m,k}$ with compact embedding.

Lemma 2.4 *If $f \in \mathcal{H}_{m,k} \cap \mathcal{H}_{m,k'}$ with $k < k'$ then $\forall \gamma \in [0; 1]$,*

$$f \in \mathcal{H}_{m, \gamma k + (1-\gamma)k'} \quad \text{and} \quad \| f \|_{\mathcal{H}_{m, \gamma k + (1-\gamma)k'}} \leq \| f \|_{\mathcal{H}_{m,k}}^\gamma \| f \|_{\mathcal{H}_{m,k'}}^{1-\gamma} .$$

Similarly, if $f \in \mathcal{H}_{m,k} \cap \mathcal{H}_{m',k}$ with $m < m'$ then $\forall \gamma \in [0; 1]$,

$$f \in \mathcal{H}_{\gamma m + (1-\gamma)m', k} \quad \text{and} \quad \| f \|_{\mathcal{H}_{\gamma m + (1-\gamma)m', k}} \leq \| f \|_{\mathcal{H}_{m,k}}^\gamma \| f \|_{\mathcal{H}_{m',k}}^{1-\gamma} .$$

3 Transformation of the problem

In this section, we show how we transform the problem (1.1) to obtain a problem where the first equation is replaced by an equation of the form

$$\frac{\partial^2}{\partial u \partial v} \tilde{\varphi}(u, v, y) = \tilde{H}(\tilde{\varphi}, u, v, y) + \Delta_y \tilde{\varphi}(u, v, y)$$

where $u = \frac{t - x^1}{2}$, $v = \frac{t + x^1}{2}$, $y = (x^2, \dots, x^n)$ and $\tilde{H}(0, u, 0, y)$ vanishes.

We notice that $N_+ = \{v = 0, u \geq 0, y \in \mathbb{R}^{n-1}\}$ and $N_- = \{u = 0, v \geq 0, y \in \mathbb{R}^{n-1}\}$.

If the function φ satisfies $\frac{\partial^2}{\partial u \partial v} \varphi = \frac{\partial^2}{\partial v \partial u} \varphi$ the equation becomes:

$$\frac{\partial^2}{\partial u \partial v} \varphi = -F(\varphi, t, x^1, y) + \Delta_y \varphi =: H(\varphi, u, v, y) + \Delta_y \varphi. \quad (3.1)$$

Concerning regularity of the functions F, φ_+, φ_- in the problem (1.1), we shall assume for the moment that there exists $m \in \mathbb{N}$ such that the following holds :

- (i) $F : (\theta, t, x^1, y) \mapsto F(\theta, t, x^1, y)$ satisfies that for any $a, b \in \mathbb{N}$, $0 \leq a \leq 1$, $0 \leq b \leq 1$, $\gamma \in \mathbb{N}$, $\mu \in \mathbb{N}^{n-1}$, $0 \leq \gamma + |\mu| \leq m + 1$, $D_t^a D_{x^1}^b D_\theta^\gamma D_y^\mu F$ is continuous in all its variables.
- (ii) φ_+ is of class C^{m+5} , φ_- C^{m+4} and φ_+, φ_- satisfy the corner condition:
 $\varphi_+(0, y) = \varphi_-(0, y)$.
- (iii) There exists a real $T > 0$ such that F, φ_+, φ_- are T -periodic in each y_i .

Remark 3.1 : The corner conditions are only those in (ii) because for the partial derivatives with respect to u or v separately, we have

$$\begin{aligned} \frac{\partial^k}{\partial u^k} \varphi(0, 0, y) &= \frac{\partial^k}{\partial u^k} \varphi_+(0, y) \\ \frac{\partial^k}{\partial v^k} \varphi(0, 0, y) &= \frac{\partial^k}{\partial v^k} \varphi_-(0, y) \end{aligned}$$

and for the partial derivatives with respect to mixed u and v , the corner conditions are assumed by the equation (3.1), namely

$$\frac{\partial^2}{\partial u \partial v} \varphi(0, 0, y) = H(\varphi(0, 0, y), 0, 0, y) + \Delta_y \varphi(0, 0, y).$$

By induction, we get higher derivatives with respect to mixed u and v at $(0, 0, y)$. △

With the definitions of H , u and v above, we see that H satisfies : for any $0 \leq a \leq 1$, $0 \leq b \leq 1$, $0 \leq \gamma + |\mu| \leq m + 1$, $D_u^a D_v^b D_\theta^\gamma D_y^\mu H$ continuous in all its variables.

After that we calculate $\frac{\partial}{\partial v} \varphi(u, 0, y)$ with the initial values as follows: we know that

$$\frac{\partial^2}{\partial u \partial v} \varphi(u, 0, y) = H(\varphi_+(u, y), u, 0, y) + \Delta_y \varphi_+(u, y)$$

(we can invert Δ_y and the limit in $v = 0$ because φ is supposed C^2 in all its variables, for the same reason we will invert ∂_v and the limit in $u = 0$ in the third line below). So by integrating in u , we obtain

$$\begin{aligned} \frac{\partial}{\partial v} \varphi(u, 0, y) &= \frac{\partial}{\partial v} \varphi(0, 0, y) + \int_0^u H(\varphi_+(s, y), s, 0, y) + \Delta_y \varphi_+(s, y) ds \\ &= \frac{\partial}{\partial v} \varphi_-(0, y) + \int_0^u H(\varphi_+(s, y), s, 0, y) + \Delta_y \varphi_+(s, y) ds. \end{aligned}$$

Then we set

$$\tilde{\varphi}(u, v, y) = \varphi(u, v, y) - (\varphi(u, 0, y) + \frac{\partial}{\partial v} \varphi(u, 0, y) v) =: \varphi(u, v, y) - \delta(\varphi_+, \varphi_-).$$

Thus $\tilde{\varphi}$ and its first derivative in v vanish at $v = 0$. On another hand, if we take the equation (3.1) and put $\tilde{\varphi}$ in it, we obtain

$$\begin{aligned} &\frac{\partial^2}{\partial u \partial v} \tilde{\varphi}(u, v, y) \\ &= H(\tilde{\varphi} + \delta(\varphi_+, \varphi_-), u, v, y) + \Delta_y(\tilde{\varphi} + \delta(\varphi_+, \varphi_-)) - \frac{\partial^2}{\partial u \partial v} \delta(\varphi_+, \varphi_-) \\ &= H(\tilde{\varphi} + \delta(\varphi_+, \varphi_-), u, v, y) + \Delta_y(\tilde{\varphi} + \delta(\varphi_+, \varphi_-)) - (H(\varphi_+(u, y), u, 0, y) + \Delta_y \varphi_+(u, y)) \\ &=: \tilde{H}(\tilde{\varphi}, u, v, y) + \Delta_y \tilde{\varphi}. \end{aligned} \tag{3.2}$$

\tilde{H} has the same regularity as H because $\delta(\varphi_+, \varphi_-)$, $\Delta_y \delta(\varphi_+, \varphi_-)$ and $\frac{\partial^2}{\partial u \partial v} \delta(\varphi_+, \varphi_-)$ are of class C^{m+1} .

If we look the value of $\tilde{H} + \Delta_y \tilde{\varphi}$ at $v = 0$ we can see that it vanishes:

$$\begin{aligned} &\tilde{H}(\tilde{\varphi}(u, 0, y), u, 0, y) + \Delta_y \tilde{\varphi}(u, 0, y) \\ &= H(\varphi(u, 0, y), u, 0, y) + \Delta_y(\varphi)(u, 0, y) - \frac{\partial^2}{\partial u \partial v} \delta(\varphi_+, \varphi_-) \\ &= H(\varphi(u, 0, y), u, 0, y) + \Delta_y(\varphi)(u, 0, y) - \frac{\partial^2}{\partial u \partial v} \varphi(u, 0, y) \\ &= 0. \end{aligned}$$

But if φ is supposed C^2 in all its variables, then $\tilde{\varphi}$ is continuous in all its variables, so we can invert Δ_y and the limit in $v = 0$, thus $\Delta_y(\tilde{\varphi})(u, v, y)|_{v=0} = 0$, hence we have

$$\tilde{H}(\tilde{\varphi}(u, 0, y), u, 0, y) = \tilde{H}(0, u, 0, y) = 0 \tag{3.3}$$

So in setting

$$\tilde{\varphi}_-(v, y) = \varphi_-(v, y) - (\varphi_+(0, y) + \frac{\partial}{\partial v}\varphi_-(0, y) v) \quad (3.4)$$

we want now to solve the problem :

$$\begin{cases} \frac{\partial^2}{\partial u \partial v} \tilde{\varphi}(u, v, y) = \tilde{H}(\tilde{\varphi}(u, v, y), u, v, y) + \Delta_y \tilde{\varphi}(u, v, y) \\ \tilde{\varphi}(u, 0, y) = 0 \\ \tilde{\varphi}(0, v, y) = \tilde{\varphi}_-(v, y) \end{cases} \quad (3.5)$$

where the assumptions of the regularity of the functions \tilde{H} and $\tilde{\varphi}_-$ are the following:

- (i) $\tilde{H} : (\theta, u, v, y) \mapsto \tilde{H}(\theta, u, v, y)$ satisfies that $\forall a, b \in \mathbb{N}$, $0 \leq a \leq 1$, $0 \leq b \leq 1$, $\gamma \in \mathbb{N}$, $\mu \in \mathbb{N}^{n-1}$, $0 \leq \gamma + |\mu| \leq m + 1$, $D_u^a D_v^b D_\theta^\gamma D_y^\mu \tilde{H}$ is continuous in all its variables (3.6)
- (ii) $\tilde{\varphi}_-$ is of class C^{m+4}
- (iii) there exists a real $T > 0$ such that $\tilde{H}, \tilde{\varphi}_-$ are T -periodic in each y_i .

4 Spectral approximation of $\tilde{\varphi}$

We take an arbitrary real number $R > 0$. Let

$$\hat{J}_\varepsilon \tilde{\varphi} = \sum_{|\alpha| \leq \frac{1}{\varepsilon}} \langle \Psi_\alpha, \tilde{\varphi} \rangle \Psi_\alpha.$$

We know that there exists a continuation of \tilde{H} in v from $[0; R]$ to $[0; 2R]$ such that for any $0 \leq a \leq 1$, $0 \leq \gamma + |\mu| \leq m + 1$ we have $D_u^a D_v^b D_\theta^\gamma D_y^\mu \tilde{H}$ continuous in all its variables (indeed, it suffices to set for $v > R$, $\tilde{H}(\theta, u, v, y) = \tilde{H}(\theta, u, R, y) + (v - R) \frac{\partial}{\partial v} \tilde{H}(\theta, u, R, y)$). The function \tilde{H} in the following will be this function multiplied by a smooth cut off function ϕ_R of v equal to 1 on $[0; R]$ and to 0 on $[\frac{3R}{4}; 2R]$. Similarly, there exists a continuation of $\tilde{\varphi}_-$ in v from $[0; R]$ to $[0; 2R]$ of class C^k in all its variables. The function $\tilde{\varphi}_-$ in the following will be this function multiplied by ϕ_R .

We will build a solution $\tilde{\varphi}_\varepsilon$ of the problem:

$$\begin{cases} \hat{J}_\varepsilon \tilde{\varphi}_\varepsilon = \tilde{\varphi}_\varepsilon \\ \frac{\partial^2}{\partial u \partial v} \tilde{\varphi}_\varepsilon(u, v, y) = \hat{J}_\varepsilon \tilde{H}(\tilde{\varphi}_\varepsilon(u, v, y), u, v, y) + \Delta_y \tilde{\varphi}_\varepsilon(u, v, y) \\ \tilde{\varphi}_\varepsilon(u, 0, y) = 0 \\ \tilde{\varphi}_\varepsilon(0, v, y) = \hat{J}_\varepsilon \tilde{\varphi}_-(v, y) \end{cases} \quad (4.1)$$

We first show the existence of the $\tilde{\varphi}_\varepsilon$. By the first equation of problem (4.1), $\tilde{\varphi}_\varepsilon$ has a finite number of components $\tilde{\varphi}_{\varepsilon, \alpha}$:

$$\tilde{\varphi}_\varepsilon(u, v, y) = \sum_{|\alpha| \leq \frac{1}{\varepsilon}} \tilde{\varphi}_{\varepsilon, \alpha}(u) \Psi_\alpha(v, y) \text{ with } \tilde{\varphi}_{\varepsilon, \alpha}(u) = \langle \Psi_\alpha(v, y), \tilde{\varphi}_{\varepsilon, \alpha}(u, v, y) \rangle.$$

We differentiate $\tilde{\varphi}_\varepsilon$ in v , after in u , on one hand, we have

$$\begin{aligned} \frac{\partial}{\partial v} \tilde{\varphi}_\varepsilon(u, v, y) &= \frac{\pi}{R} i \sum_{|\alpha| \leq \frac{1}{\varepsilon}} \alpha_0 \tilde{\varphi}_{\varepsilon, \alpha}(u) \Psi_\alpha(v, y) \\ \frac{\partial^2}{\partial u \partial v} \tilde{\varphi}_\varepsilon(u, v, y) &= \frac{\pi}{R} i \sum_{|\alpha| \leq \frac{1}{\varepsilon}} \alpha_0 \frac{\partial}{\partial u} \tilde{\varphi}_{\varepsilon, \alpha}(u) \Psi_\alpha(v, y). \end{aligned}$$

On another hand we have by using the second equation of the problem (4.1) :

$$\begin{aligned} &\frac{\partial^2}{\partial u \partial v} \tilde{\varphi}_\varepsilon(u, v, y) \\ &= \sum_{|\beta| \leq \frac{1}{\varepsilon}} \langle \Psi_\beta, \tilde{H} \left(\sum_{|\gamma| \leq \frac{1}{\varepsilon}} \tilde{\varphi}_{\varepsilon, \gamma} \Psi_\gamma, u, v, y \right) + \Delta_y \sum_{|\gamma| \leq \frac{1}{\varepsilon}} \tilde{\varphi}_{\varepsilon, \gamma} \Psi_\gamma(v, y) \rangle \Psi_\beta(v, y) \\ &= \sum_{|\beta| \leq \frac{1}{\varepsilon}} \langle \Psi_\beta, \tilde{H} \left(\sum_{|\gamma| \leq \frac{1}{\varepsilon}} \tilde{\varphi}_{\varepsilon, \gamma} \Psi_\gamma, u, v, y \right) + \sum_{j=1}^{n-1} \frac{4\pi^2}{T^2} \sum_{|\gamma| \leq \frac{1}{\varepsilon}} \gamma_j^2 \tilde{\varphi}_{\varepsilon, \gamma} \Psi_\gamma(v, y) \rangle \Psi_\beta(v, y). \end{aligned}$$

Hence with these both results, by making scalar product by Ψ_α (recall that $(\Psi_\alpha)_{\alpha \in \mathbb{Z}^n}$ is an orthonormal basis), we can identify the components:

$$\frac{\pi}{R} i \alpha_0 \frac{\partial}{\partial u} \tilde{\varphi}_{\varepsilon, \alpha}(u) = \langle \Psi_\alpha, \tilde{H} \left(\sum_{|\gamma| \leq \frac{1}{\varepsilon}} \tilde{\varphi}_{\varepsilon, \gamma} \Psi_\gamma, u, v, y \right) + \sum_{j=1}^{n-1} \frac{4\pi^2}{T^2} \sum_{|\gamma| \leq \frac{1}{\varepsilon}} \gamma_j^2 \tilde{\varphi}_{\varepsilon, \gamma} \Psi_\gamma(v, y) \rangle.$$

We can distinguish two cases. First if $\alpha_0 \neq 0$ we obtain $\frac{\partial}{\partial u} \tilde{\varphi}_{\varepsilon, \alpha}(u) = F_\alpha((\tilde{\varphi}_{\varepsilon, \beta})_{|\beta| \leq \frac{1}{\varepsilon}}, u)$ with F_α and $\frac{\partial}{\partial \tilde{\varphi}_{\varepsilon, \beta}} F_\alpha$ continuous in all their variables $((\tilde{\varphi}_{\varepsilon, \beta})_{|\beta| \leq \frac{1}{\varepsilon}}, u)$ because \tilde{H} and $D_\theta \tilde{H}$ are continuous in all their variables and \langle, \rangle is sesquilinear.

Now, if $\alpha_0 = 0$, to assume the third equation of problem (4.1) we want that $\tilde{\varphi}_\varepsilon(u, 0, y) = \sum_{|\alpha| \leq \frac{1}{\varepsilon}} \tilde{\varphi}_{\varepsilon, \alpha}(u) (2R)^{-\frac{1}{2}} T^{-\frac{n-1}{2}} e^{i\bar{\alpha} \cdot y \frac{2\pi}{T}} = 0$.

Recall that $\alpha = (\alpha_0, \bar{\alpha})$, we can decompose this sum in a sum on $\bar{\alpha}$ and a sum on α_0 , and as α_0 just intervenes in $\tilde{\varphi}_{\varepsilon, \alpha}$ we obtain : $\sum_{|\bar{\alpha}| \leq \frac{1}{\varepsilon}} \left(\sum_{\{\alpha_0: |(\alpha_0, \bar{\alpha})| \leq \frac{1}{\varepsilon}\}} \tilde{\varphi}_{\varepsilon, \alpha}(u) \right) (2R)^{-\frac{1}{2}} T^{-\frac{n-1}{2}} e^{i\bar{\alpha} \cdot y \frac{2\pi}{T}} =$

0. As this holds for every y in \mathbb{T}^{n-1} , we necessarily have

$$\forall \bar{\alpha} \text{ such that } |\bar{\alpha}| \leq \frac{1}{\varepsilon}, \quad \sum_{\{\alpha_0: |(\alpha_0, \bar{\alpha})| \leq \frac{1}{\varepsilon}\}} \tilde{\varphi}_{\varepsilon, \alpha}(u) = 0$$

hence we define $\tilde{\varphi}_{\varepsilon,(0,\bar{\alpha})}$ by

$$\forall \bar{\alpha} \text{ such that } |\bar{\alpha}| \leq \frac{1}{\varepsilon}, \quad \tilde{\varphi}_{\varepsilon,(0,\bar{\alpha})}(u) = - \sum_{\{\alpha_0 \neq 0; |(\alpha_0, \bar{\alpha})| \leq \frac{1}{\varepsilon}\}} \tilde{\varphi}_{\varepsilon,(\alpha_0, \bar{\alpha})}(u). \quad (4.2)$$

Finally all the $\tilde{\varphi}_{\varepsilon,(0,\bar{\alpha})}$ are C^1 -function of the $\tilde{\varphi}_{\varepsilon,(\alpha_0, \bar{\alpha})}$ with $\alpha_0 \neq 0$ so we can express $\frac{\partial}{\partial u} \tilde{\varphi}_{\varepsilon, \alpha}(u)$ in function of $((\tilde{\varphi}_{\varepsilon, \beta})_{\{|\beta| \leq \frac{1}{\varepsilon}; \beta_0 \neq 0\}}, u)$ as follows :

$$\forall \alpha_0 \neq 0, |\alpha| \leq \frac{1}{\varepsilon}, \quad \frac{\partial}{\partial u} \tilde{\varphi}_{\varepsilon, \alpha}(u) = \tilde{F}_\alpha((\tilde{\varphi}_{\varepsilon, \beta})_{\{|\beta| \leq \frac{1}{\varepsilon}; \beta_0 \neq 0\}}, u)$$

with \tilde{F}_α and $\frac{\partial}{\partial \tilde{\varphi}_{\varepsilon, \beta}} \tilde{F}_\alpha$ continuous in all their variables.

By the theorem of Cauchy-Lipschitz, we know that if a function f is continuous, locally Lipschitz with respect to its second variable, the problem $y' = f(t, y)$ with $y(t_0) = y_0$ has a unique C^1 -solution $y(t)$ on a maximal open interval I . Here we take

$$y = (\tilde{\varphi}_{\varepsilon, \alpha})_{\{|\alpha| \leq \frac{1}{\varepsilon}; \alpha_0 \neq 0\}} \quad f = \left(\tilde{F}_\alpha \right)_{\{|\alpha| \leq \frac{1}{\varepsilon}; \alpha_0 \neq 0\}}$$

and $y(0) = \left((2R)^{-\frac{1}{2}} T^{-\frac{n-1}{2}} \int_0^{2R} \int_{\mathbb{T}^{n-1}} e^{-i(\alpha_0 w \frac{\pi}{R} + \bar{\alpha} \cdot z \frac{2\pi}{T})} \tilde{\varphi}_-(w, z) dw d^{n-1}z \right)_{\{|\alpha| \leq \frac{1}{\varepsilon}; \alpha_0 \neq 0\}}$.

For all $\varepsilon > 0$, there exists a maximal open interval I_ε containing zero, in which we have a unique solution $\tilde{\varphi}_\varepsilon \equiv (\tilde{\varphi}_{\varepsilon, \alpha})_{\{|\alpha| \leq \frac{1}{\varepsilon}; \alpha_0 \neq 0\}}$ C^1 in u (the $(\tilde{\varphi}_{\varepsilon, \alpha})_{\{|\alpha| \leq \frac{1}{\varepsilon}; \alpha_0 = 0\}}$ are given by (4.2)).

Moreover, $\tilde{\varphi}_\varepsilon$ is smooth in (v, y) on $[0; 2R] \times \mathbb{T}^{n-1}$, so we can commute all the partial derivatives in v and y_i at any order. And as for all β in $\mathcal{I}N$, γ in $\mathcal{I}N^{n-1}$, $\frac{\partial^\beta}{\partial v^\beta} \frac{\partial^\gamma}{\partial y^\gamma} \tilde{\varphi}_\varepsilon$ is a finite sum of products of C^1 -function in u by C^1 -function in (v, y) , we have $\frac{\partial^\beta}{\partial v^\beta} \frac{\partial^\gamma}{\partial y^\gamma} \tilde{\varphi}_\varepsilon$ in $C^1(I_\varepsilon \times [0; 2R] \times \mathbb{T}^{n-1})$. So we can commute $\frac{\partial}{\partial u}$ with all the partial derivatives in v and y_i at any order.

Remark 4.1 : In all this section if we keep the expression of \tilde{H} with H and $\delta(\varphi_+, \varphi_-)$, we see that we just need the following assumptions:

- (i) $H : (\theta, u, v, y) \mapsto H(\theta, u, v, y)$ satisfies that
 - H and $\frac{\partial H}{\partial \theta}$ are continuous in all their variables
 - $\forall i = 1, \dots, n-1$, $\frac{\partial^2 H}{\partial \theta^2}, \frac{\partial^2 H}{\partial y_i \partial \theta}, \frac{\partial^2 H}{\partial \theta \partial y_i}, \frac{\partial^2 H}{\partial y_i^2}$, are continuous in variable y_i
- (ii) φ_+ is of class C^4 or H^s with $s > \frac{7}{2} + \frac{n}{2}$
- (iii) φ_- is of class C^3 or H^{s-1}
- (iv) there exists a real $T > 0$ such that H, φ_+, φ_- are T -periodic in each y_i .

(when we take φ_+ in H^s , the gain of an "half order" of derivative in comparison with the embedding $H^s \hookrightarrow C^4$ for $s > 4 + \frac{n}{2}$ comes from the fact that at a certain step we just need the continuity of φ_+ in variable y).

5 Estimation of $\| \tilde{\varphi}_\varepsilon(u) \|_{\mathcal{H}_{m,2}}$

To estimate $\| \tilde{\varphi}_\varepsilon(u) \|_{\mathcal{H}_{m,2}}$, we will first bound $\frac{d}{du} \| \tilde{\varphi}_\varepsilon(u) \|_{\mathcal{H}_{m,2}}$ by a continuous function of $\| \tilde{\varphi}_\varepsilon(u) \|_{\mathcal{H}_{m,2}}$ and then we will use the Gronwall lemma.

5.1 bound of $\frac{d}{du} \| \tilde{\varphi}_\varepsilon(u) \|_{\mathcal{H}_{m,2}}$

Proposition 5.1 *If $m > \frac{n-1}{2}$, we have the following estimation*

$$\frac{d}{du} \| \tilde{\varphi}_\varepsilon(u) \|_{\mathcal{H}_{m,2}([0;2R] \times \mathbb{T}^{n-1})}^2 \leq \mathcal{F}(\| \tilde{\varphi}_\varepsilon(u) \|_{\mathcal{H}_{m,2}([0;2R] \times \mathbb{T}^{n-1})}^2, u)$$

with \mathcal{F} continuous in both variables.

Remark 5.1 :

1) The assumption $m > \frac{n-1}{2}$ comes from the embedding $\mathcal{H}_{m,2}$ in L^∞ and so we can bound $\tilde{H}(\tilde{\varphi}_\varepsilon, u, v, y)$ by a function of the norm $\mathcal{H}_{m,2}$ of $\tilde{\varphi}_\varepsilon(u)$.

2) By writing in details the partial derivatives of \tilde{H} with the function H and $\delta(\varphi_+, \varphi_-)$, we can reduce the assumptions on φ_+, φ_- . Then, for this proposition, we can replace assumptions on φ_+, φ_- by the followings :

$$\begin{aligned} \varphi_+ &\in C^4 \cap H^{m+5} & \text{or} & \quad \varphi_+ \in H^s & \text{with} & \quad s > \frac{7}{2} + \frac{n}{2} & \text{and} & \quad s \geq m + 5 \\ \varphi_- &\in C^3 \cap H^{m+4} & \text{or} & \quad \varphi_- \in H^{s-1}. \end{aligned}$$

3) If the functions \tilde{H} and $\tilde{\varphi}_-$ are not \mathbb{T} -periodic in each y_i or not defined on \mathbb{R}^{n-1} in their variable y , we can get the existence (and uniqueness) of a solution of the problem (1.1) but in a smaller domain. We will see this in theorem 7.3.

Proof of proposition 5.1:

The proof of the proposition is organised in five steps: estimation of $\frac{d}{du} \| \tilde{\varphi}_\varepsilon(u) \|_{L^2}^2$, estimation of $\frac{d}{du} \| \frac{\partial^\beta}{\partial y^\beta} \tilde{\varphi}_\varepsilon(u) \|_{L^2}^2$, estimation of $\frac{d}{du} \| \frac{\partial}{\partial v} \frac{\partial^\beta}{\partial y^\beta} \tilde{\varphi}_\varepsilon(u) \|_{L^2}^2$, estimation of $\frac{d}{du} \| \frac{\partial^2}{\partial v^2} \frac{\partial^\beta}{\partial y^\beta} \tilde{\varphi}_\varepsilon(u) \|_{L^2}^2$, conclusion.

5.1.1 Estimation of $\frac{d}{du} \|\tilde{\varphi}_\varepsilon(u)\|_{L^2}^2$

As $\tilde{\varphi}_\varepsilon$ is in $C^1(I_\varepsilon \times [0; 2R] \times \mathbb{T}^{n-1})$ we can commute $\frac{d}{du}$ and \int so

$$\begin{aligned} \frac{d}{du} \|\tilde{\varphi}_\varepsilon(u)\|_{L^2([0; 2R] \times \mathbb{T}^{n-1})}^2 &= \int_0^{2R} \int_{\mathbb{T}^{n-1}} \frac{\partial}{\partial u} (\tilde{\varphi}_\varepsilon)^2 dv d^{n-1}y \\ &= 2 \int_0^{2R} \int_{\mathbb{T}^{n-1}} \tilde{\varphi}_\varepsilon \left(\frac{\partial}{\partial u} \tilde{\varphi}_\varepsilon \right) dv d^{n-1}y. \end{aligned}$$

As $\frac{\partial^2}{\partial v \partial u} \tilde{\varphi}_\varepsilon$ equals $\frac{\partial^2}{\partial u \partial v} \tilde{\varphi}_\varepsilon$ and so is continuous, we also have by integration in v :

$$\frac{\partial}{\partial u} (\tilde{\varphi}_\varepsilon)(u, v, y) = \frac{\partial}{\partial u} (\tilde{\varphi}_\varepsilon)(u, 0, y) + \int_0^v \frac{\partial^2}{\partial v \partial u} \tilde{\varphi}_\varepsilon(u, s, y) ds. \quad (5.1)$$

But $\tilde{\varphi}_\varepsilon$ is C^1 in variable (u, v) so we can invert in the expression $\frac{\tilde{\varphi}_\varepsilon(u+h, 0, y) - \tilde{\varphi}_\varepsilon(u, 0, y)}{h}$ the limit in $v = 0$ and the limit in $h = 0$ corresponding to $\frac{\partial}{\partial u}$. As $\tilde{\varphi}_\varepsilon(u+h, 0, y) = \tilde{\varphi}_\varepsilon(u, 0, y) = 0$ given by the third equation in (4.1) we obtain $\frac{\partial}{\partial u} (\tilde{\varphi}_\varepsilon)(u, 0, y) = 0$. Now, by using $\frac{\partial^2}{\partial v \partial u} \tilde{\varphi}_\varepsilon$ equals $\frac{\partial^2}{\partial u \partial v} \tilde{\varphi}_\varepsilon$ and the second equation of (4.1) we obtain

$$\begin{aligned} \frac{d}{du} \|\tilde{\varphi}_\varepsilon(u)\|_{L^2([0; 2R] \times \mathbb{T}^{n-1})}^2 &= 2 \int_0^{2R} \int_{\mathbb{T}^{n-1}} \tilde{\varphi}_\varepsilon(u, v, y) \int_0^v (\hat{J}_\varepsilon \tilde{H}(\tilde{\varphi}_\varepsilon, u, s, y) + \Delta_y \tilde{\varphi}_\varepsilon) ds dv d^{n-1}y. \end{aligned} \quad (5.2)$$

On one hand, by using Cauchy-Schwarz inequality in $L^2([0; v])$ and the fact that v is in $[0; 2R]$ we have for the first term of the sum in the right member of (5.2)

$$\left| \int_0^v \hat{J}_\varepsilon \tilde{H}(\tilde{\varphi}_\varepsilon, u, s, y) ds \right| \leq (2R)^{\frac{1}{2}} \|\hat{J}_\varepsilon \tilde{H}(\tilde{\varphi}_\varepsilon, u, s, y)\|_{L^2([0; 2R])}.$$

And so by definition of the norm L^2 we deduce

$$\left\| \int_0^v \hat{J}_\varepsilon \tilde{H}(\tilde{\varphi}_\varepsilon, u, s, y) ds \right\|_{L^2(\mathbb{T}^{n-1})} \leq (2R)^{\frac{1}{2}} \|\hat{J}_\varepsilon \tilde{H}(\tilde{\varphi}_\varepsilon, u, s, y)\|_{L^2([0; 2R] \times \mathbb{T}^{n-1})}.$$

By using Cauchy-Schwarz inequality in $L^2(\mathbb{T}^{n-1})$ and the inequality above, we obtain

$$\begin{aligned} \left| \int_{\mathbb{T}^{n-1}} \tilde{\varphi}_\varepsilon \int_0^v \hat{J}_\varepsilon \tilde{H}(\tilde{\varphi}_\varepsilon, u, s, y) ds \right| &\leq \|\tilde{\varphi}_\varepsilon(u, v)\|_{L^2(\mathbb{T}^{n-1})} \left\| \int_0^v \hat{J}_\varepsilon \tilde{H}(\tilde{\varphi}_\varepsilon, u, s, y) ds \right\|_{L^2(\mathbb{T}^{n-1})} \\ &\leq (2R)^{\frac{1}{2}} \|\tilde{\varphi}_\varepsilon(u, v)\|_{L^2(\mathbb{T}^{n-1})} \|\hat{J}_\varepsilon \tilde{H}(\tilde{\varphi}_\varepsilon, u, s, y)\|_{L^2([0; 2R] \times \mathbb{T}^{n-1})}. \end{aligned}$$

We know by Plancherel's theorem that for any $(2R \times T^{n-1})$ -periodic function f we have $\|f\|_{L^2}^2 = \sum_{\alpha \in \mathbb{Z}^{n+1}} |\langle \Psi_\alpha, f \rangle|^2$ so

$$\|\hat{J}_\varepsilon f\|_{L^2} \leq \|f\|_{L^2} \quad (5.3)$$

and as the function \tilde{H} is continuous we can bound as follows

$$\begin{aligned} & \left| \int_{\mathbb{T}^{n-1}} \tilde{\varphi}_\varepsilon \int_0^v \hat{J}_\varepsilon \tilde{H}(\tilde{\varphi}_\varepsilon, u, s, y) ds d^{n-1}y \right| \\ & \leq (2R)^{\frac{1}{2}} \|\tilde{\varphi}_\varepsilon(u, v)\|_{L^2(\mathbb{T}^{n-1})} \|\tilde{H}(\tilde{\varphi}_\varepsilon, u, s, y)\|_{L^2([0; 2R] \times \mathbb{T}^{n-1})} \\ & \leq (2R) T^{\frac{n-1}{2}} \|\tilde{\varphi}_\varepsilon(u, v)\|_{L^2(\mathbb{T}^{n-1})} \max_{\substack{s \in [0; 2R] \\ \theta \in \Theta_\varepsilon \\ y \in \mathbb{T}^{n-1}}} |\tilde{H}(\theta, u, s, y)| \end{aligned}$$

where $\Theta_\varepsilon = [-\|\tilde{\varphi}_\varepsilon(u)\|_{L^\infty([0; 2R] \times \mathbb{T}^{n-1})}, \|\tilde{\varphi}_\varepsilon(u)\|_{L^\infty([0; 2R] \times \mathbb{T}^{n-1})}]$ so we obtain

$$\left| \int_{\mathbb{T}^{n-1}} \tilde{\varphi}_\varepsilon \int_0^v \hat{J}_\varepsilon(\tilde{\varphi}_\varepsilon, u, s, y) ds d^{n-1}y \right| \leq c_R (\|\tilde{\varphi}_\varepsilon(u)\|_{L^\infty([0; 2R] \times \mathbb{T}^{n-1})}, u) \|\tilde{\varphi}_\varepsilon(u, v)\|_{L^2(\mathbb{T}^{n-1})}$$

with c_R continuous in all its variables.

On another hand, for the second term of the sum in the right member of (5.2), we have in the same way

$$\begin{aligned} \left| \int_{\mathbb{T}^{n-1}} \tilde{\varphi}_\varepsilon \int_0^v \Delta_y \tilde{\varphi}_\varepsilon ds d^{n-1}y \right| & \leq \|\tilde{\varphi}_\varepsilon(u, v)\|_{L^2(\mathbb{T}^{n-1})} \left\| \int_0^v \Delta_y \tilde{\varphi}_\varepsilon ds \right\|_{L^2(\mathbb{T}^{n-1})} \\ & \leq (2R)^{\frac{1}{2}} \|\tilde{\varphi}_\varepsilon(u, v)\|_{L^2(\mathbb{T}^{n-1})} \|\Delta_y \tilde{\varphi}_\varepsilon(u)\|_{L^2([0; 2R] \times \mathbb{T}^{n-1})} \\ & \leq (2R)^{\frac{1}{2}} \|\tilde{\varphi}_\varepsilon(u, v)\|_{L^2(\mathbb{T}^{n-1})} \|\tilde{\varphi}_\varepsilon(u)\|_{\mathcal{H}_{m,2}([0; 2R] \times \mathbb{T}^{n-1})}. \end{aligned}$$

Finally, we integrate in v and add these two estimations, so we obtain

$$\begin{aligned} \frac{d}{du} \|\tilde{\varphi}_\varepsilon(u)\|_{L^2([0; 2R] \times \mathbb{T}^{n-1})}^2 & \leq 2 \|\tilde{\varphi}_\varepsilon(u)\|_{L^2([0; 2R] \times \mathbb{T}^{n-1})} c_R (\|\tilde{\varphi}_\varepsilon(u)\|_{L^\infty([0; 2R] \times \mathbb{T}^{n-1})}, u) \\ & \quad + 2(2R)^{\frac{1}{2}} \|\tilde{\varphi}_\varepsilon(u)\|_{L^2([0; 2R] \times \mathbb{T}^{n-1})} \|\tilde{\varphi}_\varepsilon(u)\|_{\mathcal{H}_{m,2}([0; 2R] \times \mathbb{T}^{n-1})} \end{aligned}$$

hence as if $m > \frac{n-1}{2}$ we have $\mathcal{H}_{m,2}([0; 2R] \times \mathbb{T}^{n-1}) \subset L^\infty([0; 2R] \times \mathbb{T}^{n-1})$ (see lemma 2.2), and we can write

$$\frac{d}{du} \|\tilde{\varphi}_\varepsilon(u)\|_{L^2([0; 2R] \times \mathbb{T}^{n-1})}^2 \leq c_{1R} (\|\tilde{\varphi}_\varepsilon(u)\|_{\mathcal{H}_{m,2}([0; 2R] \times \mathbb{T}^{n-1})}, u) \quad (5.4)$$

with c_{1R} continuous in all its variables.

5.1.2 Estimation of $\frac{d}{du} \left\| \frac{\partial^\beta}{\partial y^\beta} \tilde{\varphi}_\varepsilon(u) \right\|_{L^2}^2$

Let $\beta \in \mathbb{N}^{n-1}$, $1 \leq |\beta| \leq m$, we denote $\frac{\partial^\beta}{\partial y^\beta}$ where $\beta = (\beta_1, \dots, \beta_{n-1})$ to mean that we differentiate $|\beta_i|$ times with respect to y_i .

As $\frac{\partial^\beta}{\partial y^\beta} \tilde{\varphi}_\varepsilon$ is in $C^1(I_\varepsilon \times [0; 2R] \times \mathbb{T}^{n-1})$ we can commute $\frac{d}{du}$ and \int , and after as we have done for $\frac{\partial}{\partial u} \tilde{\varphi}_\varepsilon$ in (5.1) we use that $\frac{\partial^{\beta+2}}{\partial v \partial u \partial y^\beta} \tilde{\varphi}_\varepsilon$ equals $\frac{\partial^{\beta+2}}{\partial u \partial v \partial y^\beta} \tilde{\varphi}_\varepsilon$ and so is continuous, hence

$$\begin{aligned} \frac{d}{du} \left\| \frac{\partial^\beta}{\partial y^\beta} \tilde{\varphi}_\varepsilon(u) \right\|_{L^2([0; 2R] \times \mathbb{T}^{n-1})}^2 &= 2 \int_0^{2R} \int_{\mathbb{T}^{n-1}} \frac{\partial^\beta}{\partial y^\beta} \tilde{\varphi}_\varepsilon \frac{\partial}{\partial u} \frac{\partial^\beta}{\partial y^\beta} (\tilde{\varphi}_\varepsilon) dv d^{n-1}y \\ &= 2 \int_0^{2R} \int_{\mathbb{T}^{n-1}} \frac{\partial^\beta}{\partial y^\beta} \tilde{\varphi}_\varepsilon \left[\frac{\partial}{\partial u} \left(\frac{\partial^\beta}{\partial y^\beta} \tilde{\varphi}_\varepsilon \right) (u, 0, y) \right. \\ &\quad \left. + \int_0^v \frac{\partial}{\partial v} \frac{\partial^{\beta+1}}{\partial u \partial y^\beta} (\tilde{\varphi}_\varepsilon) (u, s, y) ds \right] dv d^{n-1}y. \end{aligned}$$

We can show that $\left(\frac{\partial}{\partial u} \left(\frac{\partial^\beta}{\partial y^\beta} \tilde{\varphi}_\varepsilon \right) \right) (u, 0, y)$ equal zero in the same way as we have done for $\frac{\partial}{\partial u} (\tilde{\varphi}_\varepsilon) (u, 0, y) = 0$ because for any (u, y) in $I_\varepsilon \times \mathbb{T}^{n-1}$, we have $\tilde{\varphi}_\varepsilon(u, 0, y) = 0$, and for any $|\gamma| \leq |\beta|$, $\frac{\partial^\gamma}{\partial y^\gamma} (\tilde{\varphi}_\varepsilon)$ is in $C^1(I_\varepsilon \times [0; 2R] \times \mathbb{T}^{n-1})$ so we can invert the limits in $v = 0$ and in $h_1 = 0, \dots, h_{\beta+1} = 0$ for the partial derivatives in u and y^β .

Finally, as $\frac{\partial^{\beta+2}}{\partial v \partial u \partial y^\beta} \tilde{\varphi}_\varepsilon$ equals $\frac{\partial^{\beta+2}}{\partial y^\beta \partial v \partial u} \tilde{\varphi}_\varepsilon$ and by using the second equation of (4.1), we obtain

$$\begin{aligned} \frac{d}{du} \left\| \frac{\partial^\beta}{\partial y^\beta} \tilde{\varphi}_\varepsilon(u) \right\|_{L^2([0; 2R] \times \mathbb{T}^{n-1})}^2 &= 2 \int_0^{2R} \int_{\mathbb{T}^{n-1}} \frac{\partial^\beta}{\partial y^\beta} \tilde{\varphi}_\varepsilon \int_0^v \frac{\partial^\beta}{\partial y^\beta} (\hat{J}_\varepsilon \tilde{H}(\tilde{\varphi}_\varepsilon, u, s, y) + \Delta_y \tilde{\varphi}_\varepsilon) ds dv d^{n-1}y \end{aligned}$$

Now we will show that $\frac{\partial^\beta}{\partial y^\beta} (\hat{J}_\varepsilon (\tilde{H}(\tilde{\varphi}_\varepsilon, u, s, y))) = \hat{J}_\varepsilon \left(\frac{\partial^\beta}{\partial y^\beta} \tilde{H}(\tilde{\varphi}_\varepsilon, u, s, y) \right)$. By the defini-

tion of \hat{J}_ε , and in the end by doing an integration by parts, we have

$$\begin{aligned}
& \frac{\partial}{\partial y_i} \hat{J}_\varepsilon \tilde{H}(\tilde{\varphi}_\varepsilon, u, s, y) \\
&= \frac{\partial}{\partial y_i} \left(\sum_{|\alpha| \leq \frac{1}{\varepsilon}} (2R)^{-\frac{1}{2}} T^{-\frac{n-1}{2}} \int_0^{2R} \int_{\mathbb{T}^{n-1}} e^{-i(\alpha_0 w \frac{\pi}{R} + \bar{\alpha} \cdot z \frac{2\pi}{T})} \tilde{H}(\tilde{\varphi}_\varepsilon, u, w, z) dw d^{n-1}z \psi_\alpha(s, y) \right) \\
&= \sum_{|\alpha| \leq \frac{1}{\varepsilon}} \int_0^{2R} \int_{\mathbb{T}^{n-1}} (2R)^{-\frac{1}{2}} T^{-\frac{n-1}{2}} \left(\frac{2\pi}{T} \alpha_i \right) e^{-i(\alpha_0 w \frac{\pi}{R} + \bar{\alpha} \cdot z \frac{2\pi}{T})} \tilde{H}(\tilde{\varphi}_\varepsilon, u, w, z) dw d^{n-1}z \psi_\alpha(s, y) \\
&= \sum_{|\alpha| \leq \frac{1}{\varepsilon}} - \int_0^{2R} \int_{\mathbb{T}^{n-2}} (2R)^{-\frac{1}{2}} T^{-\frac{n-1}{2}} [e^{-i(\alpha_0 w \frac{\pi}{R} + \bar{\alpha} \cdot z \frac{2\pi}{T})} \tilde{H}(\tilde{\varphi}_\varepsilon, u, w, z)]_{z_i \in \mathbb{T}} dw d^{n-2}z \psi_\alpha(s, y) \\
&\quad + \hat{J}_\varepsilon \left(\frac{\partial}{\partial y_i} \tilde{H}(\tilde{\varphi}_\varepsilon, u, s, y) \right)
\end{aligned}$$

where $[f(z_i)]_{z_i \in \mathbb{T}}$ means $f(b) - f(a)$ if $\mathbb{T} = [a; b]$. We have supposed that \tilde{H} and $\tilde{\varphi}_-$ are \mathbb{T} -periodic in each y_i , it implies that $\tilde{\varphi}_\varepsilon$ is \mathbb{T} -periodic in each y_i (by uniqueness of solution given by the Cauchy-Lipschitz theorem in section 4), thus the first part of the second member in the equation above vanishes and we have

$$\frac{\partial}{\partial y_i} \hat{J}_\varepsilon \tilde{H}(\tilde{\varphi}_\varepsilon, u, s, y) = \hat{J}_\varepsilon \frac{\partial}{\partial y_i} \tilde{H}(\tilde{\varphi}_\varepsilon, u, s, y)$$

For higher derivatives, we proceed by recurrence with the same method (we can notice that for any $|\gamma + \nu| \leq |\beta|$, the functions $\frac{\partial^\beta}{\partial \theta^\gamma \partial y^\nu} \tilde{H}$, $\frac{\partial^\gamma}{\partial y^\gamma} \tilde{\varphi}_\varepsilon$ are also \mathbb{T} -periodic in each y_i). So the following holds:

For any $\beta \in \mathbb{N}^{n-1}$, $1 \leq \beta \leq m$,

$$\frac{\partial^\beta}{\partial y^\beta} (\hat{J}_\varepsilon \tilde{H}(\tilde{\varphi}_\varepsilon, u, s, y)) = \hat{J}_\varepsilon \left(\frac{\partial^\beta}{\partial y^\beta} \tilde{H}(\tilde{\varphi}_\varepsilon, u, s, y) \right). \quad (5.5)$$

Hence we obtain

$$\begin{aligned}
& \frac{d}{du} \left\| \frac{\partial^\beta}{\partial y^\beta} \tilde{\varphi}_\varepsilon(u) \right\|_{L^2([0; 2R] \times \mathbb{T}^{n-1})}^2 \\
&= 2 \int_0^{2R} \int_{\mathbb{T}^{n-1}} \left(\frac{\partial^\beta}{\partial y^\beta} \tilde{\varphi}_\varepsilon \right) \int_0^v [\hat{J}_\varepsilon \frac{\partial^\beta}{\partial y^\beta} \tilde{H}(\tilde{\varphi}_\varepsilon, u, s, y) + \Delta_y \tilde{\varphi}_\varepsilon] ds dv d^{n-1}y \\
&= 2 \int_0^{2R} \int_{\mathbb{T}^{n-1}} \int_0^v \left(\frac{\partial^\beta}{\partial y^\beta} \tilde{\varphi}_\varepsilon \right) [\hat{J}_\varepsilon \frac{\partial^\beta}{\partial y^\beta} \tilde{H}(\tilde{\varphi}_\varepsilon, u, s, y) + \Delta_y \tilde{\varphi}_\varepsilon] ds dv d^{n-1}y
\end{aligned}$$

(we can put $\frac{\partial^\beta}{\partial y^\beta} \tilde{\varphi}_\varepsilon$ under \int_0^v by continuity of the functions on $[0; 2R] \times \mathbb{T}^{n-1}$).

Now for the first part, as we have done before, by using the fact that v is in $[0; 2R]$, Cauchy-Schwarz inequality, and (5.3) we can bound as follows

$$\begin{aligned}
& \left| \int_{\mathbb{T}^{n-1}} \int_0^v \left(\frac{\partial^\beta}{\partial y^\beta} \tilde{\varphi}_\varepsilon \right) \hat{J}_\varepsilon \frac{\partial^\beta}{\partial y^\beta} \tilde{H}(\tilde{\varphi}_\varepsilon, u, s, y) ds d^{n-1}y \right| \\
& \leq \int_{\mathbb{T}^{n-1}} \int_0^{2R} \left| \left(\frac{\partial^\beta}{\partial y^\beta} \tilde{\varphi}_\varepsilon \right) \hat{J}_\varepsilon \frac{\partial^\beta}{\partial y^\beta} \tilde{H}(\tilde{\varphi}_\varepsilon, u, s, y) \right| ds d^{n-1}y \\
& \leq \left\| \frac{\partial^\beta}{\partial y^\beta} \tilde{\varphi}_\varepsilon(u) \right\|_{L^2([0; 2R] \times \mathbb{T}^{n-1})} \left\| \hat{J}_\varepsilon \frac{\partial^\beta}{\partial y^\beta} \tilde{H}(\tilde{\varphi}_\varepsilon, u, s, y) \right\|_{L^2([0; 2R] \times \mathbb{T}^{n-1})} \\
& \leq \left\| \frac{\partial^\beta}{\partial y^\beta} \tilde{\varphi}_\varepsilon(u) \right\|_{L^2([0; 2R] \times \mathbb{T}^{n-1})} \left\| \frac{\partial^\beta}{\partial y^\beta} \tilde{H}(\tilde{\varphi}_\varepsilon, u, s, y) \right\|_{L^2([0; 2R] \times \mathbb{T}^{n-1})}.
\end{aligned}$$

Therefore we notice that $\frac{\partial^\beta}{\partial y^\beta} \tilde{H}(\tilde{\varphi}_\varepsilon, u, s, y)$ is a sum of $\left(\frac{\partial^{\delta+\mu}}{\partial \theta^\delta \partial y^\mu} \tilde{H} \right)(\tilde{\varphi}_\varepsilon, u, s, y) \prod_{\nu} \frac{\partial^\nu}{\partial y^\nu} \tilde{\varphi}_\varepsilon(u, s, y)$

with $|\delta + \mu| \leq |\beta|$ and $\sum |\nu| \leq |\beta|$. By assumption (3.6) we know that $\frac{\partial^{\delta+\mu}}{\partial \theta^\delta \partial y^\mu} \tilde{H}$ is continuous, so when we take the norm L^2 of $\frac{\partial^\beta}{\partial y^\beta} \tilde{H}(\tilde{\varphi}_\varepsilon, u, s, y)$, we can extract it, thus we obtain

$$\begin{aligned}
& \left\| \frac{\partial^\beta}{\partial y^\beta} \tilde{H}(\tilde{\varphi}_\varepsilon, u, s, y) \right\|_{L^2([0; 2R] \times \mathbb{T}^{n-1})} \\
& \leq \sum_{|\delta+\mu| \leq |\beta|} \max_{\substack{s \in [0; 2R] \\ \theta \in \Theta_\varepsilon \\ y \in \mathbb{T}^{n-1}}} \left| \frac{\partial^{\delta+\mu}}{\partial \theta^\delta \partial y^\mu} \tilde{H}(\theta, u, s, y) \right| \left\| \prod_{\nu} \frac{\partial^\nu}{\partial y^\nu} \tilde{\varphi}_\varepsilon(u) \right\|_{L^2([0; 2R] \times \mathbb{T}^{n-1})}
\end{aligned}$$

where $\Theta_\varepsilon = [-\|\tilde{\varphi}_\varepsilon(u)\|_{L^\infty([0; 2R] \times \mathbb{T}^{n-1})}, \|\tilde{\varphi}_\varepsilon(u)\|_{L^\infty([0; 2R] \times \mathbb{T}^{n-1})}]$. Then as we know that $\tilde{\varphi}_\varepsilon(u, v)$ is in $C^0(\mathbb{T}^{n-1}) \cap H^m(\mathbb{T}^{n-1})$, we can apply the proposition 3.6 page 9 of Taylor [7] (which is still available with \mathbb{T}^{n-1} instead of \mathbb{R}^n) with $f = g = \tilde{\varphi}_\varepsilon(u, v)$, thus we get

$$\left\| \prod_{\nu} \frac{\partial^\nu}{\partial y^\nu} \tilde{\varphi}_\varepsilon(u, v) \right\|_{L^2(\mathbb{T}^{n-1})} \leq c \left\| \tilde{\varphi}_\varepsilon(u, v) \right\|_{L^\infty(\mathbb{T}^{n-1})} \left\| \tilde{\varphi}_\varepsilon(u, v) \right\|_{H^m(\mathbb{T}^{n-1})}.$$

Now we integrate the square of this inequality in v on $[0; 2R]$, it gives

$$\left\| \prod_{\nu} \frac{\partial^\nu}{\partial y^\nu} \tilde{\varphi}_\varepsilon(u) \right\|_{L^2([0; 2R] \times \mathbb{T}^{n-1})}^2 \leq c^2 \left\| \tilde{\varphi}_\varepsilon(u) \right\|_{L^\infty([0; 2R] \times \mathbb{T}^{n-1})}^2 \left\| \tilde{\varphi}_\varepsilon(u) \right\|_{\mathcal{H}_{m,0}([0; 2R] \times \mathbb{T}^{n-1})}^2.$$

Hence we have

$$\begin{aligned}
& \left\| \frac{\partial^\beta}{\partial y^\beta} \tilde{H}(\tilde{\varphi}_\varepsilon, u, s, y) \right\|_{L^2([0; 2R] \times \mathbb{T}^{n-1})} \\
& \leq c \sum_{|\delta+\mu| \leq |\beta|} \max_{\substack{s \in [0; 2R] \\ \theta \in \Theta_\varepsilon \\ y \in \mathbb{T}^{n-1}}} \left| \frac{\partial^{\delta+\mu}}{\partial \theta^\delta \partial y^\mu} \tilde{H}(\theta, u, s, y) \right| \left\| \tilde{\varphi}_\varepsilon(u) \right\|_{L^\infty} \left\| \tilde{\varphi}_\varepsilon(u) \right\|_{\mathcal{H}_{m,0}}. \quad (5.6)
\end{aligned}$$

Therefore if $m > \frac{n-1}{2}$, we obtain

$$\left| \int_{\mathbb{T}^{n-1}} \int_0^v \left(\frac{\partial^\beta}{\partial y^\beta} \tilde{\varphi}_\varepsilon \right) \hat{J}_\varepsilon \frac{\partial^\beta}{\partial y^\beta} \tilde{H}(\tilde{\varphi}_\varepsilon, u, s, y) ds d^{n-1}y \right| \leq C_{2R} (\| \tilde{\varphi}_\varepsilon(u) \|_{\mathcal{H}_{m,2}([0;2R] \times \mathbb{T}^{n-1})}, u)$$

with C_{2R} continuous in all its variables.

Then by integrating in v on $[0; 2R]$

$$\begin{aligned} 2 \int_0^{2R} \int_{\mathbb{T}^{n-1}} \int_0^v \left(\frac{\partial^\beta}{\partial y^\beta} \tilde{\varphi}_\varepsilon \right) \hat{J}_\varepsilon \frac{\partial^\beta}{\partial y^\beta} \tilde{H}(\tilde{\varphi}_\varepsilon, u, s, y) ds dv d^{n-1}y \\ \leq 2RC_{2R} (\| \tilde{\varphi}_\varepsilon(u) \|_{\mathcal{H}_{m,2}([0;2R] \times \mathbb{T}^{n-1})}, u). \end{aligned}$$

On another hand, for the second part, by continuity of the functions we can commute $\int_{\mathbb{T}^{n-1}}$ and \int_0^v , and as $\frac{\partial^{\beta-1}}{\partial y^{\beta-1}} \tilde{\varphi}_\varepsilon$ is \mathbb{T} -periodic in each y_i , we have by integrating by parts in each y_i on \mathbb{T} :

$$\begin{aligned} 2 \int_0^{2R} \int_{\mathbb{T}^{n-1}} \int_0^v \frac{\partial^\beta}{\partial y^\beta} \tilde{\varphi}_\varepsilon \frac{\partial^\beta}{\partial y^\beta} \Delta_y \tilde{\varphi}_\varepsilon ds dv d^{n-1}y \\ = 2 \int_0^{2R} \int_0^v - \sum_{j=1}^{n-1} \int_{\mathbb{T}^{n-1}} \frac{\partial}{\partial y_j} \left(\frac{\partial^\beta}{\partial y^\beta} \tilde{\varphi}_\varepsilon \right) \frac{\partial}{\partial y_j} \left(\frac{\partial^\beta}{\partial y^\beta} \tilde{\varphi}_\varepsilon \right) dv ds d^{n-1}y \\ = -2 \sum_{j=1}^{n-1} \int_0^{2R} \int_0^v \int_{\mathbb{T}^{n-1}} \left(\frac{\partial}{\partial y_j} \frac{\partial^\beta}{\partial y^\beta} \tilde{\varphi}_\varepsilon \right)^2 dv ds d^{n-1}y \\ \leq 0. \end{aligned}$$

Thus

$$\frac{d}{du} \left\| \frac{\partial^\beta}{\partial y^\beta} \tilde{\varphi}_\varepsilon(u) \right\|_{L^2([0;2R] \times \mathbb{T}^{n-1})}^2 \leq 2RC_{2R} (\| \tilde{\varphi}_\varepsilon(u) \|_{\mathcal{H}_{m,2}([0;2R] \times \mathbb{T}^{n-1})}, u) \quad (5.7)$$

5.1.3 Estimation of $\frac{d}{du} \left\| \frac{\partial}{\partial v} \frac{\partial^\beta}{\partial y^\beta} \tilde{\varphi}_\varepsilon(u) \right\|_{L^2}^2$

For any $\beta \in \mathbb{N}^{n-1}$, $0 \leq |\beta| \leq m$, as $\frac{\partial}{\partial v} \frac{\partial^\beta}{\partial y^\beta} \tilde{\varphi}_\varepsilon$ is in $C^1(I_\varepsilon \times [0; 2R] \times \mathbb{T}^{n-1})$ we can commute $\frac{d}{du}$ and \int , and $\frac{\partial^{\beta+2}}{\partial u \partial v \partial y^\beta} \tilde{\varphi}_\varepsilon$ equals $\frac{\partial^{\beta+2}}{\partial y^\beta \partial u \partial v} \tilde{\varphi}_\varepsilon$, we have

$$\frac{d}{du} \left\| \frac{\partial}{\partial v} \frac{\partial^\beta}{\partial y^\beta} \tilde{\varphi}_\varepsilon(u) \right\|_{L^2([0;2R] \times \mathbb{T}^{n-1})}^2 = 2 \int_0^{2R} \int_{\mathbb{T}^{n-1}} \left(\frac{\partial^{\beta+1}}{\partial v \partial y^\beta} \tilde{\varphi}_\varepsilon \right) \frac{\partial^\beta}{\partial y^\beta} \left(\frac{\partial^2}{\partial u \partial v} \tilde{\varphi}_\varepsilon \right) dv d^{n-1}y.$$

Then by using the second equation of (4.1) and (5.5), we obtain

$$\begin{aligned} \frac{d}{du} \left\| \frac{\partial}{\partial v} \frac{\partial^\beta}{\partial y^\beta} \tilde{\varphi}_\varepsilon(u) \right\|_{L^2([0;2R] \times \mathbb{T}^{n-1})}^2 \\ = 2 \int_0^{2R} \int_{\mathbb{T}^{n-1}} \left(\frac{\partial^{\beta+1}}{\partial v \partial y^\beta} \tilde{\varphi}_\varepsilon \right) \left(\hat{J}_\varepsilon \frac{\partial^\beta}{\partial y^\beta} \tilde{H}(\tilde{\varphi}_\varepsilon, u, v, y) + \frac{\partial^\beta}{\partial y^\beta} \Delta_y \tilde{\varphi}_\varepsilon \right) dv d^{n-1}y. \end{aligned}$$

As we have done in (5.6), we can deduce that

$$\left| \int_0^{2R} \int_{\mathbb{T}^{n-1}} \left(\frac{\partial^{\beta+1}}{\partial v \partial y^\beta} \tilde{\varphi}_\varepsilon \right) \hat{J}_\varepsilon \frac{\partial^\beta}{\partial y^\beta} \tilde{H}(\tilde{\varphi}_\varepsilon, u, s, y) dv d^{n-1}y \right| \leq C_{3R}(\| \tilde{\varphi}_\varepsilon(u) \|_{\mathcal{H}_{m,2}([0;2R] \times \mathbb{T}^{n-1})}, u)$$

with C_{3R} continuous in all its variables.

For the second part, by integrating by parts in each y_i on \mathbb{T} , as $\frac{\partial^{\beta+1}}{\partial v \partial y^\beta} \tilde{\varphi}_\varepsilon$ and $\frac{\partial^{\beta+1}}{\partial y_j \partial y^\beta} \tilde{\varphi}_\varepsilon$ are \mathbb{T} -periodic in each y_i , we have :

$$\int_0^{2R} \int_{\mathbb{T}^{n-1}} \left(\frac{\partial^{\beta+1}}{\partial v \partial y^\beta} \tilde{\varphi}_\varepsilon \right) \frac{\partial^\beta}{\partial y^\beta} \Delta_y \tilde{\varphi}_\varepsilon dv d^{n-1}y = \int_0^{2R} - \sum_{j=1}^{n-1} \int_{\mathbb{T}^{n-1}} \frac{\partial}{\partial y_j} \left(\frac{\partial^{\beta+1}}{\partial v \partial y^\beta} \tilde{\varphi}_\varepsilon \right) \frac{\partial}{\partial y_j} \frac{\partial^\beta}{\partial y^\beta} \tilde{\varphi}_\varepsilon dv d^{n-1}y.$$

We know that $\frac{\partial}{\partial y_j} \frac{\partial^{\beta+1}}{\partial v \partial y^\beta} \tilde{\varphi}_\varepsilon = \frac{\partial}{\partial v} \frac{\partial^{\beta+1}}{\partial y_j \partial y^\beta} \tilde{\varphi}_\varepsilon$, thus

$$\begin{aligned} \int_0^{2R} \int_{\mathbb{T}^{n-1}} \left(\frac{\partial^{\beta+1}}{\partial v \partial y^\beta} \tilde{\varphi}_\varepsilon \right) \frac{\partial^\beta}{\partial y^\beta} \Delta_y \tilde{\varphi}_\varepsilon dv d^{n-1}y &= - \sum_{j=1}^{n-1} \int_{\mathbb{T}^{n-1}} \int_0^{2R} \frac{\partial}{\partial v} \left(\frac{\partial^{\beta+1}}{\partial y_j \partial y^\beta} \tilde{\varphi}_\varepsilon \right) \frac{\partial^{\beta+1}}{\partial y_j \partial y^\beta} \tilde{\varphi}_\varepsilon dv d^{n-1}y \\ &= - \sum_{j=1}^{n-1} \int_{\mathbb{T}^{n-1}} \frac{1}{2} \left[\left(\frac{\partial^{\beta+1}}{\partial y_j \partial y^\beta} \tilde{\varphi}_\varepsilon \right)^2 \right] d^{n-1}y. \end{aligned}$$

But $\frac{\partial^{\beta+1}}{\partial y_j \partial y^\beta} \tilde{\varphi}_\varepsilon(u, 0, y) = 0$, indeed it comes from the third equation of (4.1) and the continuity of all the functions $\frac{\partial^\gamma}{\partial y^\gamma} \tilde{\varphi}_\varepsilon$ on $[0; 2R] \times \mathbb{T}^{n-1}$, so we get

$$\begin{aligned} \int_0^{2R} \int_{\mathbb{T}^{n-1}} \left(\frac{\partial^{\beta+1}}{\partial v \partial y^\beta} \tilde{\varphi}_\varepsilon \right) \frac{\partial^\beta}{\partial y^\beta} \Delta_y \tilde{\varphi}_\varepsilon dv d^{n-1}y &= - \sum_{j=1}^{n-1} \int_{\mathbb{T}^{n-1}} \frac{1}{2} \left(\frac{\partial^{\beta+1}}{\partial y_j \partial y^\beta} \tilde{\varphi}_\varepsilon(u, 2R, y) \right)^2 d^{n-1}y \\ &\leq 0. \end{aligned}$$

Finally, we have if $m > n - 1$,

$$\frac{d}{du} \left\| \frac{\partial}{\partial v} \frac{\partial^\beta}{\partial y^\beta} \tilde{\varphi}_\varepsilon(u) \right\|_{L^2([0;2R] \times \mathbb{T}^{n-1})}^2 \leq C_{3R}(\| \tilde{\varphi}_\varepsilon(u) \|_{\mathcal{H}_{m,2}([0;2R] \times \mathbb{T}^{n-1})}, u) \quad (5.8)$$

with C_{3R} continuous in all its variables.

5.1.4 Estimation of $\frac{d}{du} \left\| \frac{\partial^2}{\partial v^2} \frac{\partial^\beta}{\partial y^\beta} \tilde{\varphi}_\varepsilon(u) \right\|_{L^2}^2$

For any $\beta \in \mathbb{N}^{n-1}$, $0 \leq |\beta| \leq m$, as $\frac{\partial^2}{\partial v^2} \frac{\partial^\beta}{\partial y^\beta} \tilde{\varphi}_\varepsilon$ is in $C^1(I_\varepsilon \times [0; 2R] \times \mathbb{T}^{n-1})$ and $\frac{\partial^{\beta+3}}{\partial u \partial v^2 \partial y^\beta} \tilde{\varphi}_\varepsilon$ equals $\frac{\partial^{\beta+3}}{\partial v \partial y^\beta \partial u \partial v} \tilde{\varphi}_\varepsilon$ we can proceed as before, so

$$\begin{aligned} \frac{d}{du} \left\| \frac{\partial^2}{\partial v^2} \frac{\partial^\beta}{\partial y^\beta} \tilde{\varphi}_\varepsilon(u) \right\|_{L^2([0; 2R] \times \mathbb{T}^{n-1})}^2 &= 2 \int_0^{2R} \int_{\mathbb{T}^{n-1}} \left(\frac{\partial^{\beta+2}}{\partial v^2 \partial y^\beta} \tilde{\varphi}_\varepsilon \right) \frac{\partial^{\beta+1}}{\partial v \partial y^\beta} \left(\frac{\partial^2}{\partial u \partial v} \tilde{\varphi}_\varepsilon \right) dv d^{n-1}y \\ &= 2 \int_0^{2R} \int_{\mathbb{T}^{n-1}} \left(\frac{\partial^{\beta+2}}{\partial v^2 \partial y^\beta} \tilde{\varphi}_\varepsilon \right) \frac{\partial^{\beta+1}}{\partial v \partial y^\beta} (\hat{J}_\varepsilon \tilde{H}(\tilde{\varphi}_\varepsilon, u, v, y) + \Delta_y \tilde{\varphi}_\varepsilon) dv d^{n-1}y. \end{aligned} \quad (5.9)$$

We estimate the first part of (5.9) corresponding to the first term in the sum beyond. By (5.5) we have

$$\frac{\partial^{\beta+1}}{\partial v \partial y^\beta} (\hat{J}_\varepsilon \tilde{H}(\tilde{\varphi}_\varepsilon, u, v, y)) = \frac{\partial}{\partial v} \left(\hat{J}_\varepsilon \frac{\partial^\beta}{\partial y^\beta} (\tilde{H}(\tilde{\varphi}_\varepsilon, u, v, y)) \right).$$

Now by integrating by parts on $[0; 2R]$, we obtain

$$\begin{aligned} &\frac{\partial}{\partial v} \left(\hat{J}_\varepsilon \frac{\partial^\beta}{\partial y^\beta} (\tilde{H}(\tilde{\varphi}_\varepsilon, u, v, y)) \right) \\ &= \sum_{|\alpha| \leq \frac{1}{\varepsilon}} \int_0^{2R} \int_{\mathbb{T}^{n-1}} (2R)^{-\frac{1}{2}} T^{-\frac{n-1}{2}} \left(\frac{\pi}{R} \alpha_0 \right) e^{-i(\alpha_0 w \frac{\pi}{R} + \bar{\alpha} \cdot z \frac{2\pi}{T})} \frac{\partial^\beta}{\partial y^\beta} (\tilde{H}(\tilde{\varphi}_\varepsilon, u, w, z)) dw d^{n-1}z \psi_\alpha(s, y) \\ &= \sum_{|\alpha| \leq \frac{1}{\varepsilon}} - \int_{\mathbb{T}^{n-1}} (2R)^{-\frac{1}{2}} T^{-\frac{n-1}{2}} [e^{-i(\alpha_0 w \frac{\pi}{R} + \bar{\alpha} \cdot z \frac{2\pi}{T})}]_0^{2R} \frac{\partial^\beta}{\partial y^\beta} (\tilde{H}(\tilde{\varphi}_\varepsilon, u, w, z)) d^{n-1}z \psi_\alpha(s, y) \\ &\quad + \hat{J}_\varepsilon \frac{\partial^{\beta+1}}{\partial v \partial y^\beta} (\tilde{H}(\tilde{\varphi}_\varepsilon, u, v, y)) \end{aligned}$$

where $[f(w)]_0^{2R}$ means $f(2R) - f(0)$.

But $\frac{\partial^\beta}{\partial y^\beta} (\tilde{H}(\tilde{\varphi}_\varepsilon(u, 2R, z), u, 2R, z)) = 0$, indeed \tilde{H} is a product of a function f by $v \mapsto \phi_R(v)$, so for any ν such that $|\nu| \leq |\beta|$, $\frac{\partial^\nu}{\partial y^\nu} \tilde{H} = \phi_R \frac{\partial^\nu}{\partial y^\nu} f$ and $\phi_R(2R) = 0$.

On another hand, $\frac{\partial^\beta}{\partial y^\beta}(\tilde{H}(\tilde{\varphi}_\varepsilon(u, 0, z), u, 0, z)) = 0$. Indeed

$$\begin{aligned} & \frac{\partial}{\partial y_i}(\tilde{H}(\tilde{\varphi}_\varepsilon(u, v, y), u, v, y)) \\ &= \left(\frac{\partial}{\partial y_i}\tilde{H}\right)(\tilde{\varphi}_\varepsilon(u, v, y), u, v, y) + \left(\frac{\partial}{\partial \theta}\tilde{H}\right)(\tilde{\varphi}_\varepsilon(u, v, y), u, v, y)\left(\frac{\partial}{\partial y_i}\tilde{\varphi}_\varepsilon\right)(u, v, y). \end{aligned}$$

For the first term, $\tilde{\varphi}_\varepsilon(u, 0, z) = 0$ and we can invert in the expression $(\tilde{H}(\theta, u, v, y + he_i) - \tilde{H}(\theta, u, v, y))/h$ the limit in $(\theta, v) = (0, 0)$ and the limit in $h = 0$ corresponding to $\frac{\partial}{\partial y_i}$ because of the regularity of \tilde{H} . As $\tilde{H}(0, u, 0, y) = 0$ for any (u, y) (see (3.3)), this first term vanishes at $v = 0$. For the second term, we already have seen that $(\frac{\partial}{\partial y_i}\tilde{\varphi}_\varepsilon)(u, 0, y) = 0$ so it vanishes at $v = 0$. For higher derivatives we proceed similarly.

Hence we obtain

$$\frac{\partial^{\beta+1}}{\partial v \partial y^\beta}(\hat{J}_\varepsilon \tilde{H}(\tilde{\varphi}_\varepsilon, u, v, y)) = \hat{J}_\varepsilon\left(\frac{\partial^{\beta+1}}{\partial v \partial y^\beta}(\tilde{H}(\tilde{\varphi}_\varepsilon, u, v, y))\right). \quad (5.10)$$

Remark 5.2 : We can see here that we can't get an estimation with higher derivatives than two in v . Indeed, in $\frac{\partial^2}{\partial v^2}\hat{J}_\varepsilon \tilde{H}(\tilde{\varphi}_\varepsilon, u, v, y)$ appears a term $\frac{\partial}{\partial \theta}\tilde{H}(\tilde{\varphi}_\varepsilon(u, 0, y), u, 0, y)\frac{\partial}{\partial v}\tilde{\varphi}_\varepsilon(u, 0, y)$ under the sum on $|\alpha| \leq \frac{1}{\varepsilon}$ and there's no reason for it to vanish. Then if we keep it, the estimation contains a factor of type $c(\frac{1}{\varepsilon})$ which is not uniformly bounded as ε goes to 0.

Now we can write that if $m > \frac{n-1}{2}$,

$$\begin{aligned} & 2 \int_0^{2R} \int_{\mathbb{T}^{n-1}} \left(\frac{\partial^{\beta+2}}{\partial v^2 \partial y^\beta}\tilde{\varphi}_\varepsilon\right)\hat{J}_\varepsilon\left(\frac{\partial^{\beta+1}}{\partial v \partial y^\beta}\tilde{H}(\tilde{\varphi}_\varepsilon, u, v, y)\right)dv \, d^{n-1}y \\ & \leq 2 \left\| \frac{\partial^{\beta+2}}{\partial v^2 \partial y^\beta}\tilde{\varphi}_\varepsilon \right\|_{L^2([0;2R] \times \mathbb{T}^{n-1})} \left\| \hat{J}_\varepsilon \frac{\partial^{\beta+1}}{\partial v \partial y^\beta}\tilde{H}(\tilde{\varphi}_\varepsilon, u, v, y) \right\|_{L^2([0;2R] \times \mathbb{T}^{n-1})} \\ & \leq 2 \left\| \frac{\partial^{\beta+2}}{\partial v^2 \partial y^\beta}\tilde{\varphi}_\varepsilon \right\|_{L^2([0;2R] \times \mathbb{T}^{n-1})} \left\| \frac{\partial^{\beta+1}}{\partial v \partial y^\beta}\tilde{H}(\tilde{\varphi}_\varepsilon, u, v, y) \right\|_{L^2([0;2R] \times \mathbb{T}^{n-1})} \\ & \leq C_{4R}(\|\tilde{\varphi}_\varepsilon(u)\|_{\mathcal{H}_{m,2}([0;2R] \times \mathbb{T}^{n-1})}, u) \end{aligned}$$

because of the assumptions (3.6) on \tilde{H} , with C_{4R} continuous in all its variables. Indeed we bound the second factor of the right member above as we have done in (5.6), by applying the proposition 3.6 page 9 of Taylor [7] with $f = \tilde{\varphi}_\varepsilon(u, v)$ and $g = \frac{\partial}{\partial v}\tilde{\varphi}_\varepsilon(u, v)$, it gives

$$\begin{aligned} & \left\| \frac{\partial^{\nu_1}}{\partial y^{\nu_1}}\tilde{\varphi}_\varepsilon(u, v) \frac{\partial^{\nu_2+1}}{\partial y^{\nu_2} \partial v}\tilde{\varphi}_\varepsilon(u, v) \right\|_{L^2(\mathbb{T}^{n-1})} \\ & \leq c \left\| \tilde{\varphi}_\varepsilon(u, v) \right\|_{L^\infty(\mathbb{T}^{n-1})} \left\| \frac{\partial}{\partial v}\tilde{\varphi}_\varepsilon(u, v) \right\|_{H^m(\mathbb{T}^{n-1})} \\ & \quad + c' \left\| \frac{\partial}{\partial v}\tilde{\varphi}_\varepsilon(u, v) \right\|_{L^\infty(\mathbb{T}^{n-1})} \left\| \tilde{\varphi}_\varepsilon(u, v) \right\|_{H^m(\mathbb{T}^{n-1})}. \end{aligned}$$

We integrate the square of this inequality in v on $[0; 2R]$, use that $(A+B)^2 \leq 2(A^2+B^2)$, thus we obtain by taking the square root and as $\sqrt{A+B} \leq \sqrt{A} + \sqrt{B}$,

$$\begin{aligned} & \left\| \frac{\partial^{\nu_1}}{\partial y^{\nu_1}} \tilde{\varphi}_\varepsilon(u, v) \frac{\partial^{\nu_2+1}}{\partial y^{\nu_2} \partial v} \tilde{\varphi}_\varepsilon(u, v) \right\|_{L^2([0; 2R] \times \mathbb{T}^{n-1})} \\ & \leq \sqrt{(2)c} \left\| \tilde{\varphi}_\varepsilon(u) \right\|_{L^\infty([0; 2R] \times \mathbb{T}^{n-1})} \left\| \frac{\partial}{\partial v} \tilde{\varphi}_\varepsilon(u) \right\|_{\mathcal{H}_{m,0}([0; 2R] \times \mathbb{T}^{n-1})} \\ & \quad + \sqrt{(2)c'} \left\| \frac{\partial}{\partial v} \tilde{\varphi}_\varepsilon(u) \right\|_{L^\infty([0; 2R] \times \mathbb{T}^{n-1})} \left\| \tilde{\varphi}_\varepsilon(u) \right\|_{\mathcal{H}_{m,0}([0; 2R] \times \mathbb{T}^{n-1})}. \end{aligned}$$

Then as $\frac{\partial}{\partial v} \tilde{\varphi}_\varepsilon(u)$ is in $\mathcal{H}_{m,1}$ and as if $m > \frac{n-1}{2}$, we have the embedding $\mathcal{H}_{m,1}$ in L^∞ , we get

$$\left\| \frac{\partial^{\beta+1}}{\partial v \partial y^\beta} \tilde{H}(\tilde{\varphi}_\varepsilon, u, v, y) \right\|_{L^2([0; 2R] \times \mathbb{T}^{n-1})} \leq \bar{c} \left\| \tilde{\varphi}_\varepsilon(u) \right\|_{\mathcal{H}_{m,2}}$$

with \bar{c} continuous.

Now, we estimate the second part of (5.9) corresponding to the second term. We know that we can commute any partial derivatives in v and in y_i on $\tilde{\varphi}_\varepsilon$. By integrating by parts in each y_i on \mathbb{T} , as $\frac{\partial^{\beta+2}}{\partial v^2 \partial y^\beta} \tilde{\varphi}_\varepsilon$ and $\frac{\partial^{\beta+2}}{\partial v \partial y^\beta \partial y_i} \tilde{\varphi}_\varepsilon$ are \mathbb{T} -periodic, we obtain

$$\begin{aligned} & 2 \int_0^{2R} \int_{\mathbb{T}^{n-1}} \left(\frac{\partial^{\beta+2}}{\partial v^2 \partial y^\beta} \tilde{\varphi}_\varepsilon \right) \frac{\partial^{\beta+1}}{\partial v \partial y^\beta} (\Delta_y(\tilde{\varphi}_\varepsilon)) dv d^{n-1}y \\ & = -2 \int_0^{2R} \sum_{i=1}^n \int_{\mathbb{T}^{n-1}} \frac{\partial}{\partial v} \left(\frac{\partial^{\beta+2}}{\partial v \partial y_i \partial y^\beta} \tilde{\varphi}_\varepsilon \right) \left(\frac{\partial^{\beta+2}}{\partial v \partial y_i \partial y^\beta} \tilde{\varphi}_\varepsilon \right) dv d^{n-1}y \\ & = - \int_0^{2R} \sum_{i=1}^n \int_{\mathbb{T}^{n-1}} \frac{\partial}{\partial v} \left(\frac{\partial^{\beta+2}}{\partial v \partial y_i \partial y^\beta} \tilde{\varphi}_\varepsilon \right)^2 dv d^{n-1}y \\ & = - \sum_{i=1}^n \int_{\mathbb{T}^{n-1}} \left(\frac{\partial^{\beta+2}}{\partial v \partial y_i \partial y^\beta} \tilde{\varphi}_\varepsilon \right)^2(u, 2R, y) - \left(\frac{\partial^{\beta+2}}{\partial v \partial y_i \partial y^\beta} \tilde{\varphi}_\varepsilon \right)^2(u, 0, y) d^{n-1}y. \end{aligned}$$

The first term is less or equal to zero. For the second one, as $\frac{\partial}{\partial v} \frac{\partial}{\partial y_i} \frac{\partial^{\beta}}{\partial y^\beta} \tilde{\varphi}_\varepsilon$ is in $C^1(I_\varepsilon \times [0; 2R] \times \mathbb{T}^{n-1})$ we can write

$$\left(\frac{\partial^{\beta+2}}{\partial v \partial y_i \partial y^\beta} \tilde{\varphi}_\varepsilon \right)(u, 0, y) = \left(\frac{\partial^{\beta+2}}{\partial v \partial y_i \partial y^\beta} \tilde{\varphi}_\varepsilon \right)(0, 0, y) + \int_0^u \left(\frac{\partial^{\beta+3}}{\partial u \partial v \partial y_i \partial y^\beta} \tilde{\varphi}_\varepsilon \right)(s, 0, y) ds.$$

Then as $\tilde{\varphi}_\varepsilon(0, v, y) = \hat{J}_\varepsilon \tilde{\varphi}_-(v, y)$, and by the fact that we can commute the partial derivatives, we have

$$\begin{aligned} & \left(\frac{\partial^{\beta+2}}{\partial v \partial y_i \partial y^\beta} \tilde{\varphi}_\varepsilon \right)(u, 0, y) \\ & = \left(\frac{\partial^{\beta+2}}{\partial v \partial y_i \partial y^\beta} \hat{J}_\varepsilon \tilde{\varphi}_- \right)(0, y) + \int_0^u \left(\frac{\partial^{\beta+1}}{\partial y_i \partial y^\beta} \hat{J}_\varepsilon \tilde{H}(\tilde{\varphi}_\varepsilon, s, 0, y) + \frac{\partial^{\beta+1}}{\partial y_i \partial y^\beta} \Delta_y \tilde{\varphi}_\varepsilon(s, 0, y) \right) ds. \end{aligned}$$

We have seen in (5.5) that we can commute \hat{J}_ε with the partial derivatives with respect to y , and $\frac{\partial^{\beta+1}}{\partial y_i \partial y^\beta} \tilde{H}(\tilde{\varphi}_\varepsilon, u, v, y)$ is a sum of $(\frac{\partial^{\delta+\mu}}{\partial \theta^\delta \partial y^\mu} \tilde{H})(\tilde{\varphi}_\varepsilon, u, v, y) \prod_{\nu} \frac{\partial^\nu}{\partial y^\nu} \tilde{\varphi}_\varepsilon(u, v, y)$ with $|\delta + \mu| \leq |\beta| + 1$ and $\sum |\nu| \leq |\beta| + 1$. But we know that $\tilde{\varphi}_\varepsilon(u, 0, y) = 0$ so $\frac{\partial^\nu}{\partial y^\nu} \tilde{\varphi}_\varepsilon(u, 0, y) = 0$ and for the term $(\frac{\partial^{\beta+1}}{\partial y_i \partial y^\beta} \tilde{H})(\tilde{\varphi}_\varepsilon(s, 0, y), s, 0, y) = (\frac{\partial^{\beta+1}}{\partial y_i \partial y^\beta} \tilde{H})(0, s, 0, y)$, as $\tilde{H}(0, s, 0, y) = 0$ it vanishes. Thus it only stays $(\frac{\partial^{\beta+2}}{\partial v \partial y_i \partial y^\beta} \hat{J}_\varepsilon \tilde{\varphi}_-)(0, y)$. We show that

$$\frac{\partial^{\beta+2}}{\partial v \partial y_i \partial y^\beta} \hat{J}_\varepsilon \tilde{\varphi}_- = \hat{J}_\varepsilon \frac{\partial^{\beta+2}}{\partial v \partial y_i \partial y^\beta} \tilde{\varphi}_-$$

by proceeding as we have done in (5.10) because $\tilde{\varphi}_-$ is T-periodic, $\tilde{\varphi}_-$ is a product with a factor ϕ_R and $\frac{\partial^{\beta+1}}{\partial y_i \partial y^\beta} \tilde{\varphi}_-(0, z) = 0$. Indeed by (3.4)

$$\frac{\partial^{\beta+1}}{\partial y_i \partial y^\beta} \tilde{\varphi}_-(w, z) = \frac{\partial^{\beta+1}}{\partial y_i \partial y^\beta} \varphi_-(w, z) - \frac{\partial^{\beta+1}}{\partial y_i \partial y^\beta} \varphi_+(0, z) - \frac{\partial^{\beta+1}}{\partial y_i \partial y^\beta} \frac{\partial}{\partial v} \varphi_-(0, z) w$$

hence

$$\frac{\partial^{\beta+1}}{\partial y_i \partial y^\beta} \tilde{\varphi}_-(0, z) = \frac{\partial^{\beta+1}}{\partial y_i \partial y^\beta} \varphi_-(0, z) - \frac{\partial^{\beta+1}}{\partial y_i \partial y^\beta} \varphi_+(0, z) = 0$$

by the corner condition $\varphi_-(0, y) = \varphi_+(0, y)$. Now as $\|\hat{J}_\varepsilon f\|_{L^2(\mathbb{T}^{n-1})} \leq \|f\|_{L^2(\mathbb{T}^{n-1})}$, we get

$$\begin{aligned} \sum_{i=1}^n \int_{\mathbb{T}^{n-1}} (\frac{\partial^{\beta+2}}{\partial v \partial y_i \partial y^\beta} \tilde{\varphi}_\varepsilon)^2(u, 0, y) d^{n-1}y &= \sum_{i=1}^n \int_{\mathbb{T}^{n-1}} (\frac{\partial^{\beta+2}}{\partial v \partial y_i \partial y^\beta} \tilde{\varphi}_-)^2(0, y) d^{n-1}y \\ &\leq \sum_{i=1}^n \|\frac{\partial^{\beta+2}}{\partial v \partial y_i \partial y^\beta} \tilde{\varphi}_-(0)\|_{L^2(\mathbb{T}^{n-1})}^2 \leq \tilde{c} \end{aligned}$$

by the assumptions on $\tilde{\varphi}_-$.

Finally, we obtain if $m > \frac{n-1}{2}$,

$$\frac{d}{du} \|\frac{\partial^2}{\partial v^2} \frac{\partial^\beta}{\partial y^\beta} \tilde{\varphi}_\varepsilon(u)\|_{L^2([0;2R] \times \mathbb{T}^{n-1})}^2 \leq C_{4R} (\|\tilde{\varphi}_\varepsilon(u)\|_{\mathcal{H}_{m,2}([0;2R] \times \mathbb{T}^{n-1})}, u) \quad (5.11)$$

with C_{4R} continuous in all its variables.

5.1.5 Conclusion

Now it suffices to add (5.4), (5.7), (5.8), (5.11), and we can conclude that if $m > \frac{n-1}{2}$,

$$\frac{d}{du} \|\tilde{\varphi}_\varepsilon(u)\|_{\mathcal{H}_{m,2}([0;2R] \times \mathbb{T}^{n-1})}^2 \leq \mathcal{F}(\|\tilde{\varphi}_\varepsilon(u)\|_{\mathcal{H}_{m,2}([0;2R] \times \mathbb{T}^{n-1})}, u)$$

with \mathcal{F} continuous in both variables.

5.2 bound of $\| \tilde{\varphi}_\varepsilon(u) \|_{\mathcal{H}_{m,2}([0;2R] \times \mathbb{T}^{n-1})}$

Proposition 5.2 *If $m > \frac{n-1}{2}$, there exists a interval $[0; B_R[$ and a function $h_R : [0; B_R[\rightarrow \mathbb{R}$ such that*

(i) $\tilde{\varphi}_\varepsilon$ exist on $[0; B_R[\times [0; 2R] \times \mathbb{T}^{n-1}$

(ii) we have the following estimation for all u in $[0; B_R[$

$$\| \tilde{\varphi}_\varepsilon(u) \|_{\mathcal{H}_{m,2}([0;2R] \times \mathbb{T}^{n-1})} \leq h_R(u)$$

with h_R continuous in its variable.

Proof:

We first apply the nonlinear differential Gronwall's lemma, recall if f is $C^1(I)$ with I real interval including 0, $f(0) \leq M$, $\frac{df}{dt} \leq F(f, t)$, and F continuous then there exists $I(M)$ including 0 and a continuous function $G_M : t \mapsto G_M(t)$ defined on $I(M)$ such that $f(t) \leq G_M(t)$ on $I \cap I(M) \cap \mathbb{R}^+$.

Here $f(u) = \| \tilde{\varphi}_\varepsilon(u) \|_{\mathcal{H}_{m,2}([0;2R] \times \mathbb{T}^{n-1})}^2$, $f(0) = \| \tilde{\varphi}_- \|_{\mathcal{H}_{m,2}([0;2R] \times \mathbb{T}^{n-1})}^2 \leq c(R)$ and $I = I_\varepsilon$.

So there exists $I(c(R))$ including 0 and $G_R : u \mapsto G_R(u)$ continuous and defined on $I(c(R))$ such that $\| \tilde{\varphi}_\varepsilon(u) \|_{\mathcal{H}_{m,2}([0;2R] \times \mathbb{T}^{n-1})}^2 \leq G_R(u)$ for all u in $I_\varepsilon \cap I(c(R)) \cap \mathbb{R}^+$.

Let $[0; B_R[= I(c(R)) \cap \mathbb{R}^+$. Now we want to show that $[0; B_R[$ is included in I_ε . Let $I_\varepsilon =] - T_\varepsilon^-; T_\varepsilon^+[$ the maximal interval of existence of $\tilde{\varphi}_\varepsilon$ with respect to its variable u . Suppose that $T_\varepsilon^+ < B_R$, we set $c^2 = \max_{0 \leq u \leq T_\varepsilon^+} G_R(u)$ then we have

$$\| \tilde{\varphi}_\varepsilon(u) \|_{\mathcal{H}_{m,2}([0;2R] \times \mathbb{T}^{n-1})} \leq c \text{ on } [0; T_\varepsilon^+ - \frac{T}{2}] \quad (\text{for any } T < 2T_\varepsilon^+).$$

Let $K = [0; 2T_\varepsilon^+]$, $c > 0$, by the theorem of Cauchy-Lipschitz, there exists $T_{c,K} > 0$ such that the solution of

$$(*) \quad \left(\frac{\partial \tilde{\varphi}_{\varepsilon,\alpha}}{\partial u} \right)_{\{|\alpha| \leq \frac{1}{\varepsilon}; \alpha_0 \neq 0\}} = \left(\tilde{F}_\alpha((\tilde{\varphi}_{\varepsilon,\beta})_{\{|\beta| \leq \frac{1}{\varepsilon}; \beta_0 \neq 0\}}, u) \right)_{\{|\alpha| \leq \frac{1}{\varepsilon}; \alpha_0 \neq 0\}}$$

with the initial value $\tilde{\varphi}_\varepsilon(t_0)$ ($t_0 \in K$) satisfying $\| \tilde{\varphi}_\varepsilon(t_0) \|_{\mathcal{H}_{m,2}([0;2R] \times \mathbb{T}^{n-1})} \leq c$, exists on $[t_0; t_0 + T_{c,K}]$.

Let $v_\varepsilon(u) = \tilde{\varphi}_\varepsilon(u)$ for all u in $[0; T_\varepsilon^+ - \frac{T_{c,K}}{2}]$, and $v_\varepsilon(u)$ solution of $(*)$ with, at $t_0 = T_\varepsilon^+ - \frac{T_{c,K}}{2}$ $v_\varepsilon(T_\varepsilon^+ - \frac{T_{c,K}}{2}) = \tilde{\varphi}_\varepsilon(T_\varepsilon^+ - \frac{T_{c,K}}{2})$ (indeed $\| \tilde{\varphi}_\varepsilon(T_\varepsilon^+ - \frac{T_{c,K}}{2}) \|_{\mathcal{H}_{m,2}([0;2R] \times \mathbb{T}^{n-1})} \leq c$).

Hence v_ε exists on $[T_\varepsilon^+ - \frac{T_{c,K}}{2}; T_\varepsilon^+ + \frac{T_{c,K}}{2}]$, v_ε is a solution on $[0; T_\varepsilon^+ + \frac{T_{c,K}}{2}]$, which is contrary of maximality of $] - T_\varepsilon^-; T_\varepsilon^+[$. So we obtain that $[0; B_R[$ is included in I_ε .

6 Existence of $\tilde{\varphi}$

We can show now the following proposition

Proposition 6.1 *If $m > \frac{n-1}{2} + 2$, there exists a solution $\tilde{\varphi}$ for the problem (3.5) with assumptions (3.6), and this solution is in $C^0([0; R] \times \mathbb{T}^{n-1})$.*

Moreover, if $m > \max(n-1, \frac{n-1}{2} + 2)$ then $\tilde{\varphi}$ is in $C^0(I \times [0; R] \times \mathbb{T}^{n-1})$.

Moreover, for all $l \geq 2$, if $m > \max(n-1, \frac{n-1}{2} + 4 + l)$, and if for any $0 \leq a \leq l-1$, $0 \leq b \leq l-1$, $0 \leq \gamma + |\mu| \leq m+1$, $D_t^a D_{x^1}^b D_\theta^\gamma D_y^\mu F$ is continuous in all its variables. then $\tilde{\varphi}$ is in $C^l(I \times [0; R] \times \mathbb{T}^{n-1})$.

Remark 6.1 : We suppose that $n \geq 2$, the results for the case $n = 1$ state in section 8.

6.1 Proof of the proposition 6.1

In the first step we prove the existence of a solution $\tilde{\varphi}$, then in the second step we study its regularity.

6.1.1 Existence of a solution of the problem (3.5)

We have shown in the proposition 5.2 that for any $\varepsilon > 0$, $\tilde{\varphi}_\varepsilon$ exist on $[0; B_R] \times [0; R] \times \mathbb{T}^{n-1}$ and $\forall u \in [0; B_R]$, $\|\tilde{\varphi}_\varepsilon(u)\|_{\mathcal{H}_{m,2}([0;R] \times \mathbb{T}^{n-1})} \leq h_R(u)$ with h_R continuous.

So on $I = [0; \frac{B_R}{2}]$ we have $\|\tilde{\varphi}_\varepsilon(u)\|_{\mathcal{H}_{m,2}([0;R] \times \mathbb{T}^{n-1})} \leq \max_I h_R = c$.

Thus for any u in I , $\tilde{\varphi}_\varepsilon(u)$ is bounded in $\mathcal{H}_{m,2}([0; R] \times \mathbb{T}^{n-1})$. As this space is reflexive, we can extract a sub-sequence $\tilde{\varphi}_{\varepsilon'}(u)$ which weakly converges to $\tilde{\varphi}(u)$ in $\mathcal{H}_{m,2}$ and $\|\tilde{\varphi}(u)\|_{\mathcal{H}_{m,2}} \leq \liminf \|\tilde{\varphi}_\varepsilon(u)\|_{\mathcal{H}_{m,2}} \leq c$ so $\tilde{\varphi}$ is in $L^\infty(I, \mathcal{H}_{m,2}([0; R] \times \mathbb{T}^{n-1}))$.

By compactness of embedding $\mathcal{H}_{m,2} \hookrightarrow \mathcal{H}_{m,0}$ (see lemma 2.3), if $(\tilde{\varphi}_{\varepsilon'}(u))$ weakly converges to $\tilde{\varphi}(u)$ in $\mathcal{H}_{m,2}$, then $(\tilde{\varphi}_{\varepsilon'}(u))$ strongly converges to $\tilde{\varphi}(u)$ in $\mathcal{H}_{m,0}$. By interpolation (see lemma (2.4) with $\nu = \frac{k}{2}$), if $0 < k < 2$ we have

$$\begin{aligned} \|\tilde{\varphi}_{\varepsilon'}(u) - \tilde{\varphi}_\varepsilon(u)\|_{\mathcal{H}_{m,k}} &\leq \|\tilde{\varphi}_{\varepsilon'}(u) - \tilde{\varphi}_\varepsilon(u)\|_{\mathcal{H}_{m,0}}^{\frac{k}{2}} \|\tilde{\varphi}_{\varepsilon'}(u) - \tilde{\varphi}_\varepsilon(u)\|_{\mathcal{H}_{m,2}}^{\frac{2-k}{2}} \\ &\leq \|\tilde{\varphi}_{\varepsilon'}(u) - \tilde{\varphi}_\varepsilon(u)\|_{\mathcal{H}_{m,0}}^{\frac{k}{2}} (\|\tilde{\varphi}_{\varepsilon'}(u)\|_{\mathcal{H}_{m,2}} + \|\tilde{\varphi}_\varepsilon(u)\|_{\mathcal{H}_{m,2}})^{\frac{2-k}{2}} \\ &\leq \|\tilde{\varphi}_{\varepsilon'}(u) - \tilde{\varphi}_\varepsilon(u)\|_{\mathcal{H}_{m,0}}^{\frac{k}{2}} (2c)^{\frac{2-k}{2}}. \end{aligned}$$

From which we can deduce that $(\tilde{\varphi}_{\varepsilon'}(u))$ strongly converges to $\tilde{\varphi}(u)$ in $\mathcal{H}_{m,k}$.

In particular, if $k = 1$, by inclusion $\mathcal{H}_{m,1} \subset C^0$ (see lemma 2.2) we see that $(\tilde{\varphi}_{\varepsilon'}(u))$ strongly converges to $\tilde{\varphi}(u)$ in $C^0([0; R] \times \mathbb{T}^{n-1})$.

Then by continuity of \tilde{H} , we get $(\tilde{H}(\tilde{\varphi}_{\varepsilon'}(u), u))$ strongly converges to $\tilde{H}(\tilde{\varphi}(u), u)$ in $C^0([0; R] \times \mathbb{T}^{n-1})$.

Now by observing that

$$\begin{aligned} \|\hat{J}_{\varepsilon'}\tilde{H}(\tilde{\varphi}_{\varepsilon'}(u), u) - \tilde{H}(\tilde{\varphi}(u), u)\|_{C^0} &\leq \|\hat{J}_{\varepsilon'}\tilde{H}(\tilde{\varphi}_{\varepsilon'}(u), u) - \tilde{H}(\tilde{\varphi}_{\varepsilon'}(u), u)\|_{C^0} \\ &\quad + \|\tilde{H}(\tilde{\varphi}_{\varepsilon'}(u), u) - \tilde{H}(\tilde{\varphi}(u), u)\|_{C^0} \end{aligned}$$

and that

$$\|\hat{J}_{\varepsilon'}\tilde{H}(\tilde{\varphi}_{\varepsilon'}(u), u) - \tilde{H}(\tilde{\varphi}_{\varepsilon'}(u), u)\|_{C^0} \leq \|\hat{J}_{\varepsilon'} - Id\|_{\mathcal{L}(L^2, H^1)} \|\tilde{H}(\tilde{\varphi}_{\varepsilon'}(u), u)\|_{C^0}$$

with $\|\hat{J}_{\varepsilon'} - Id\|_{\mathcal{L}(L^2, H^1)} \rightarrow 0$ and $\|\tilde{H}(\tilde{\varphi}_{\varepsilon'}(u), u)\|_{C^0}$ bounded, we can show that

$$\hat{J}_{\varepsilon'}\tilde{H}(\tilde{\varphi}_{\varepsilon'}(u), u) \rightarrow \tilde{H}(\tilde{\varphi}(u), u) \quad \text{in } C^0([0; R] \times \mathbb{T}^{n-1}). \quad (6.1)$$

Now we show the convergence of the partial derivative of $\tilde{\varphi}_{\varepsilon'}$ with respect to v . We have

$$\left\| \frac{\partial}{\partial v} \tilde{\varphi}_{\varepsilon'}(u) \right\|_{\mathcal{H}_{m,1}} \leq \|\tilde{\varphi}_{\varepsilon'}(u)\|_{\mathcal{H}_{m,2}} \leq c$$

and $\mathcal{H}_{m,1}$ is reflexive so we can extract a subsequence $(\frac{\partial}{\partial v} \tilde{\varphi}_{\varepsilon^n}(u))$ of $(\frac{\partial}{\partial v} \tilde{\varphi}_{\varepsilon'}(u))$ which weakly converges in $\mathcal{H}_{m,1}$ (then strongly in $\mathcal{H}_{m-1,1}$ by compactness of the embedding $\mathcal{H}_{m,1} \hookrightarrow \mathcal{H}_{m-1,1}$) to $\tilde{\varphi}(u) \in \mathcal{H}_{m,1}$ and $\|\tilde{\varphi}(u)\|_{\mathcal{H}_{m,1}} \leq c$.

Now we verify that $\tilde{\varphi}(u) = \frac{\partial}{\partial v} \tilde{\varphi}(u)$. Weakly convergence in $\mathcal{H}_{m,1}([0; R] \times \mathbb{T}^{n-1})$ implies weakly convergence in $L^2([0; R] \times \mathbb{T}^{n-1})$, itself implies convergence in $\mathcal{D}'([0; R] \times \mathbb{T}^{n-1})$. So on one hand, $\frac{\partial}{\partial v} \tilde{\varphi}_{\varepsilon^n}(u) \rightarrow \tilde{\varphi}(u)$ in $\mathcal{D}'([0; R] \times \mathbb{T}^{n-1})$ and on another hand $\tilde{\varphi}_{\varepsilon^n}(u) \rightarrow \tilde{\varphi}(u)$ in $\mathcal{D}'([0; R] \times \mathbb{T}^{n-1})$, hence $\frac{\partial}{\partial v} \tilde{\varphi}_{\varepsilon^n}(u) \rightarrow \frac{\partial}{\partial v} \tilde{\varphi}(u)$ in $\mathcal{D}'([0; R] \times \mathbb{T}^{n-1})$. By uniqueness of the limit in $\mathcal{D}'([0; R] \times \mathbb{T}^{n-1})$ we get $\tilde{\varphi}(u) = \frac{\partial}{\partial v} \tilde{\varphi}(u)$.

In the following we see that $\frac{\partial}{\partial v} \tilde{\varphi}_{\varepsilon^n}(u)$ converges to $\frac{\partial}{\partial v} \tilde{\varphi}(u)$ in $C^0([0; R] \times \mathbb{T}^{n-1})$. It suffices to apply the argument of interpolation:

for all μ such that $1 < \mu < m$ let σ defined by $\mu = \sigma + (1 - \sigma)m$, we have

$$\begin{aligned} \left\| \frac{\partial}{\partial v} \tilde{\varphi}_{\varepsilon^n}(u) - \frac{\partial}{\partial v} \tilde{\varphi}(u) \right\|_{\mathcal{H}_{\mu,1}} &\leq \left\| \frac{\partial}{\partial v} \tilde{\varphi}_{\varepsilon^n}(u) - \frac{\partial}{\partial v} \tilde{\varphi}(u) \right\|_{\mathcal{H}_{1,1}}^{\sigma} \left\| \frac{\partial}{\partial v} \tilde{\varphi}_{\varepsilon^n}(u) - \frac{\partial}{\partial v} \tilde{\varphi}(u) \right\|_{\mathcal{H}_{m,1}}^{1-\sigma} \\ &\leq \left\| \frac{\partial}{\partial v} \tilde{\varphi}_{\varepsilon^n}(u) - \frac{\partial}{\partial v} \tilde{\varphi}(u) \right\|_{\mathcal{H}_{1,1}}^{\sigma} (2c)^{1-\sigma}. \end{aligned}$$

Thus

$$\left\| \frac{\partial}{\partial v} \tilde{\varphi}_{\varepsilon^n}(u) - \frac{\partial}{\partial v} \tilde{\varphi}(u) \right\|_{\mathcal{H}_{\mu,1}} \rightarrow 0.$$

In particular, if we choose $m - 1 < \mu < m$, as $m - 1 > \frac{n-1}{2}$ $\mathcal{H}_{\mu,1} \hookrightarrow C^0$, so

$$\left\| \frac{\partial}{\partial v} \tilde{\varphi}_{\varepsilon^n}(u) - \frac{\partial}{\partial v} \tilde{\varphi}(u) \right\|_{C^0([0; R] \times \mathbb{T}^{n-1})} \rightarrow 0. \quad (6.2)$$

Similarly, we can show the following lemma that we need for the moment with $D_y^\alpha = \Delta_y$:

Lemma 6.1 *If $m - |\alpha| > \frac{n-1}{2}$, $D_y^\alpha \tilde{\varphi}(u)$ is in $C^0([0; R] \times \mathbb{T}^{n-1})$.*

Proof of lemma 6.1:

For all $|\alpha| < m$, we have $\| D_y^\alpha \tilde{\varphi}_{\varepsilon^n}(u) \|_{\mathcal{H}_{m-|\alpha|,2}} \leq \| \tilde{\varphi}_{\varepsilon^n}(u) \|_{\mathcal{H}_{m,2}} \leq c$. So we can extract a subsequence (that we will denote also $\tilde{\varphi}_{\varepsilon^n}$ for more commodity) weakly convergent in $\mathcal{H}_{m-|\alpha|,2}$ then strongly in $\mathcal{H}_{m-|\alpha|,1}$. Arguing by uniqueness of the limit in $\mathcal{D}'([0; R] \times \mathbb{T}^{n-1})$, we show that its limit is $D_y^\alpha \tilde{\varphi}(u)$.

By interpolation, for all $0 < k < 2$, $\| D_y^\alpha \tilde{\varphi}_{\varepsilon^n}(u) - D_y^\alpha \tilde{\varphi}(u) \|_{\mathcal{H}_{m-|\alpha|,k}} \rightarrow 0$. In particular, if $k = 1$, as $m - |\alpha| > \frac{n-1}{2}$ by embedding $\mathcal{H}_{m-|\alpha|,1} \hookrightarrow C^0$, we get

$$\| D_y^\alpha \tilde{\varphi}_{\varepsilon^n}(u) - D_y^\alpha \tilde{\varphi}(u) \|_{C^0([0;R] \times \mathbb{T}^{n-1})} \rightarrow 0.$$

Then as $C^0([0; R] \times \mathbb{T}^{n-1})$ is a complete space, we get that $D_y^\alpha \tilde{\varphi}(u)$ is in $C^0([0; R] \times \mathbb{T}^{n-1})$.

\triangle

By applying this lemma with $D_y^\alpha = \frac{\partial^2}{\partial y_i^2}$ and adding on $i = 1, \dots, n-1$, we obtain that if $m > 2 + \frac{n-1}{2}$, $\Delta_y \tilde{\varphi}(u)$ is in $C^0([0; R] \times \mathbb{T}^{n-1})$. We will deduce from these results that $\tilde{\varphi}$ is a solution of the problem (3.5). Indeed, on one hand, from the continuity of $\frac{\partial^2}{\partial u \partial v} \tilde{\varphi}_{\varepsilon^n}(u)$ we have

$\frac{\partial}{\partial v} \tilde{\varphi}_{\varepsilon^n}(u) - \frac{\partial}{\partial v} \tilde{\varphi}_{\varepsilon^n}(0) = \int_0^u \frac{\partial^2}{\partial u \partial v} \tilde{\varphi}_{\varepsilon^n}(\sigma) d\sigma$. Therefore we use the theorem of dominated convergence of Lebesgue. By the convergence of $\Delta_y \tilde{\varphi}_{\varepsilon^n}(\sigma)$ and (6.1) we can say that, for all σ in I , $\frac{\partial^2}{\partial u \partial v} \tilde{\varphi}_{\varepsilon^n}(\sigma) = \hat{J}_{\varepsilon^n} \tilde{H}(\tilde{\varphi}_{\varepsilon^n}(\sigma), \sigma) + \Delta_y \tilde{\varphi}_{\varepsilon^n}(\sigma)$ converges to $\tilde{H}(\tilde{\varphi}(\sigma), \sigma) + \Delta_y \tilde{\varphi}(\sigma)$ in $C^0([0; R] \times \mathbb{T}^{n-1})$.

And $\| \frac{\partial^2}{\partial u \partial v} \tilde{\varphi}_{\varepsilon^n} \|_{L^\infty(I, C^0([0;R] \times \mathbb{T}^{n-1}))} = \max_{\sigma \in I} \| \hat{J}_{\varepsilon^n} \tilde{H}(\tilde{\varphi}_{\varepsilon^n}(\sigma), \sigma) + \Delta_y \tilde{\varphi}_{\varepsilon^n}(\sigma) \|_{C^0([0;R] \times \mathbb{T}^{n-1})} \leq \bar{c}_R$ which is in $L^1([0, u])$.

So $\int_0^u \frac{\partial^2}{\partial u \partial v} \tilde{\varphi}_{\varepsilon^n}(\sigma) d\sigma \rightarrow \int_0^u \tilde{H}(\tilde{\varphi}(\sigma), \sigma) + \Delta_y \tilde{\varphi}(\sigma) d\sigma$ in $C^0([0; R] \times \mathbb{T}^{n-1})$. Furthermore, $\frac{\partial}{\partial v} \tilde{\varphi}_{\varepsilon^n}(u) - \frac{\partial}{\partial v} \tilde{\varphi}_{\varepsilon^n}(0) \rightarrow \int_0^u \tilde{H}(\tilde{\varphi}(\sigma), \sigma) + \Delta_y \tilde{\varphi}(\sigma) d\sigma$ in $C^0([0; R] \times \mathbb{T}^{n-1})$.

On another hand, by (6.2) $\frac{\partial}{\partial v} \tilde{\varphi}_{\varepsilon^n}(u) - \frac{\partial}{\partial v} \tilde{\varphi}_{\varepsilon^n}(0) \rightarrow \frac{\partial}{\partial v} \tilde{\varphi}(u) - \frac{\partial}{\partial v} \tilde{\varphi}(0)$ in $C^0([0; R] \times \mathbb{T}^{n-1})$. Hence by uniqueness of the limit in $C^0([0; R] \times \mathbb{T}^{n-1})$ we get

$$\frac{\partial}{\partial v} \tilde{\varphi}(u) - \frac{\partial}{\partial v} \tilde{\varphi}(0) = \int_0^u \tilde{H}(\tilde{\varphi}(\sigma), \sigma) + \Delta_y \tilde{\varphi}(\sigma) d\sigma.$$

Then we differentiate with respect to u and we obtain

$$\frac{\partial^2}{\partial u \partial v} \tilde{\varphi}(u, v, y) = \tilde{H}(\tilde{\varphi}(u, v, y), u, v, y) + \Delta_y \tilde{\varphi}(u, v, y). \quad (6.3)$$

We notice that $\tilde{\varphi}(u, 0, y) = 0$ is given by $\tilde{\varphi}_{\varepsilon^n}(u, 0, y) = 0$ and the convergence of $\tilde{\varphi}_{\varepsilon^n}(u)$ in $C^0([0; R] \times \mathbb{T}^{n-1})$.

For the last equation of the problem (3.5), we recall that $\tilde{\varphi}_{\varepsilon^n}(0, v, y) = \hat{J}_{\varepsilon^n} \tilde{\varphi}_-(v, y)$, and as

$$\| \hat{J}_{\varepsilon^n} \tilde{\varphi}_- - \tilde{\varphi}_- \|_{C^0} \leq \| \hat{J}_{\varepsilon^n} - Id \|_{\mathcal{L}(L^2, H^1)} \| \tilde{\varphi}_- \|_{C^0}$$

with $\| \hat{J}_{\varepsilon^n} - Id \|_{\mathcal{L}(L^2, H^1)} \rightarrow 0$ and $\| \tilde{\varphi}_- \|_{C^0}$ finite, we can show that

$$\hat{J}_{\varepsilon^n} \tilde{\varphi}_- \rightarrow \tilde{\varphi}_- \quad \text{in } C^0([0; R] \times \mathbb{T}^{n-1}).$$

Now with the convergence of $\tilde{\varphi}_{\varepsilon^n}(0)$ in $C^0([0; R] \times \mathbb{T}^{n-1})$ and the uniqueness of the limit we can conclude that $\tilde{\varphi}(0, v, y) = \tilde{\varphi}_-(v, y)$.

6.1.2 Regularity of $\tilde{\varphi}$

Now we are going to show that $\tilde{\varphi}$ is $C^0(I \times [0; R] \times \mathbb{T}^{n-1})$. To reach this goal, we will show that $\tilde{\varphi}$ is in $C^{0,1}(I, \mathcal{H}_{m',1}([0; R] \times \mathbb{T}^{n-1}))$ with $m' > (n-1)/2$. By the continuity in v of $\frac{\partial}{\partial v} \tilde{\varphi}$, we can write :

$$\tilde{\varphi}(u+h, v, y) - \tilde{\varphi}(u, v, y) = \tilde{\varphi}(u+h, 0, y) - \tilde{\varphi}(u, 0, y) + \int_0^v \frac{\partial}{\partial v} (\tilde{\varphi}(u+h, \sigma, y) - \tilde{\varphi}(u, \sigma, y)) d\sigma.$$

Let $m' = m/2$, as we have seen beyond $\tilde{\varphi}(u+h, 0, y) = 0$ and $\tilde{\varphi}(u, 0, y) = 0$, so

$$\| \tilde{\varphi}(u+h) - \tilde{\varphi}(u) \|_{\mathcal{H}_{m',1}([0;R] \times \mathbb{T}^{n-1})} = \| \int_0^v \frac{\partial}{\partial v} (\tilde{\varphi}(u+h, \sigma, y) - \tilde{\varphi}(u, \sigma, y)) d\sigma \|_{\mathcal{H}_{m',1}([0;R] \times \mathbb{T}^{n-1})} \quad (6.4)$$

Here we need the following lemma, the proof of which can be found in appendix B:

Lemma 6.2 *Suppose that f is a function of (s, y) such that for all $0 \leq \nu \leq m'$, $D_y^\nu f$ is in $C^0([0; R] \times \mathbb{T}^{n-1})$, then*

$$\| \int_0^v f(s, y) ds \|_{\mathcal{H}_{m',1}([0;R] \times \mathbb{T}^{n-1})} \leq (R^{\frac{3}{2}} + 1) \| f(s, y) \|_{\mathcal{H}_{m',0}([0;R] \times \mathbb{T}^{n-1})}$$

Here by using lemma 6.1 with $\alpha = \nu$, we get that if $m - m' > (n-1)/2$ i.e. $m > n-1$, then for all $0 \leq |\nu| \leq m'$, $D_y^\nu \tilde{\varphi}(u)$ is in $C^0([0; R] \times \mathbb{T}^{n-1})$. So we can apply the lemma 6.2 on $\frac{\partial}{\partial v} \tilde{\varphi}(u+h, s, y) - \frac{\partial}{\partial v} \tilde{\varphi}(u, s, y)$, and by observing that $\| f(s, y) \|_{\mathcal{H}_{m',0}([0;R] \times \mathbb{T}^{n-1})} \leq \| f(s, y) \|_{\mathcal{H}_{m',1}([0;R] \times \mathbb{T}^{n-1})}$ we can write that

$$\begin{aligned} & \| \int_0^v \frac{\partial}{\partial v} \tilde{\varphi}(u+h, \sigma, y) - \frac{\partial}{\partial v} \tilde{\varphi}(u, \sigma, y) d\sigma \|_{\mathcal{H}_{m',1}([0;R] \times \mathbb{T}^{n-1})} \\ & \leq (R^{\frac{3}{2}} + 1) \| \frac{\partial}{\partial v} \tilde{\varphi}(u+h, \sigma, y) - \frac{\partial}{\partial v} \tilde{\varphi}(u, \sigma, y) \|_{\mathcal{H}_{m',1}([0;R] \times \mathbb{T}^{n-1})}. \end{aligned} \quad (6.5)$$

On another hand we know that for all $1 < \mu < m$,

$$\| \frac{\partial}{\partial v} \tilde{\varphi}_{\varepsilon^n}(u) - \frac{\partial}{\partial v} \tilde{\varphi}(u) \|_{\mathcal{H}_{\mu,1}([0;R] \times \mathbb{T}^{n-1})} \rightarrow 0.$$

Hence

$$\| \frac{\partial}{\partial v} \tilde{\varphi}(u+h) - \frac{\partial}{\partial v} \tilde{\varphi}(u) \|_{\mathcal{H}_{\mu,1}} = \lim_{\varepsilon^n \rightarrow 0} \| \frac{\partial}{\partial v} \tilde{\varphi}_{\varepsilon^n}(u+h) - \frac{\partial}{\partial v} \tilde{\varphi}_{\varepsilon^n}(u) \|_{\mathcal{H}_{\mu,1}}.$$

Recall that $\frac{\partial^2}{\partial u \partial v} \tilde{\varphi}_{\varepsilon^n}$ is continuous in all its variables (u, v, y) , so we have

$$\| \frac{\partial}{\partial v} \tilde{\varphi}(u+h) - \frac{\partial}{\partial v} \tilde{\varphi}(u) \|_{\mathcal{H}_{\mu,1}} = \lim_{\varepsilon^n \rightarrow 0} \| \int_u^{u+h} \frac{\partial^2}{\partial u \partial v} \tilde{\varphi}_{\varepsilon^n}(\sigma) d\sigma \|_{\mathcal{H}_{\mu,1}}.$$

Then we need the following lemma, the proof of which can be found in appendix B:

Lemma 6.3 *If $(u, v, y) \mapsto f(u, v, y)$ is a function such that for all $0 \leq |\nu| \leq \mu$, $0 \leq a \leq 1$, $D_v^a D_y^\nu f$ is continuous in all its variables, then*

$$\left\| \int_u^{u+h} f(\sigma) d\sigma \right\|_{\mathcal{H}_{\mu,1}} \leq \int_u^{u+h} \left\| f(\sigma) \right\|_{\mathcal{H}_{\mu,1}} d\sigma.$$

Now we apply the lemma above to $f = \frac{\partial^2}{\partial u \partial v} \tilde{\varphi}_{\varepsilon^n}$, so we obtain

$$\left\| \frac{\partial}{\partial v} \tilde{\varphi}(u+h) - \frac{\partial}{\partial v} \tilde{\varphi}(u) \right\|_{\mathcal{H}_{\mu,1}} \leq \lim_{\varepsilon^n \rightarrow 0} \int_u^{u+h} \left\| \frac{\partial^2}{\partial u \partial v} \tilde{\varphi}_{\varepsilon^n}(\sigma) \right\|_{\mathcal{H}_{\mu,1}} d\sigma.$$

But

$$\begin{aligned} \left\| \frac{\partial^2}{\partial u \partial v} \tilde{\varphi}_{\varepsilon^n}(\sigma) \right\|_{\mathcal{H}_{\mu,1}} &= \left\| \hat{J}_{\varepsilon^n} \tilde{H}(\tilde{\varphi}_{\varepsilon^n}(\sigma), \sigma) + \Delta_y \tilde{\varphi}_{\varepsilon^n}(\sigma) \right\|_{\mathcal{H}_{\mu,1}} \\ &\leq \left\| \tilde{H}(\tilde{\varphi}_{\varepsilon^n}(\sigma), \sigma) \right\|_{\mathcal{H}_{\mu,1}} + \left\| \Delta_y \tilde{\varphi}_{\varepsilon^n}(\sigma) \right\|_{\mathcal{H}_{\mu,1}} \\ &\leq c_R (\left\| \tilde{\varphi}_{\varepsilon^n}(\sigma) \right\|_{L^\infty, \sigma} (1 + \left\| \tilde{\varphi}_{\varepsilon^n}(\sigma) \right\|_{\mathcal{H}_{\mu,1}}) + \left\| \tilde{\varphi}_{\varepsilon^n}(\sigma) \right\|_{\mathcal{H}_{\mu+2,1}}) \end{aligned}$$

with $\left\| \tilde{\varphi}_{\varepsilon^n}(\sigma) \right\|_{L^\infty, \sigma}$, $\left\| \tilde{\varphi}_{\varepsilon^n}(\sigma) \right\|_{\mathcal{H}_{\mu,1}}$, $\left\| \tilde{\varphi}_{\varepsilon^n}(\sigma) \right\|_{\mathcal{H}_{\mu+2,1}}$ bounded on I . Hence,

$$\left\| \frac{\partial^2}{\partial u \partial v} \tilde{\varphi}_{\varepsilon^n}(\sigma) \right\|_{\mathcal{H}_{\mu,1}} \leq \bar{c}_R.$$

Thus, we have with $\mu = m'$ (as $n \geq 2$ and $m' = \frac{m}{2} = \frac{1}{2} \max(n-1; \frac{n-1}{2} + 2)$ we get $1 < m' < m$)

$$\left\| \frac{\partial}{\partial v} \tilde{\varphi}(u+h) - \frac{\partial}{\partial v} \tilde{\varphi}(u) \right\|_{\mathcal{H}_{\mu,1}([0;R] \times \mathbb{T}^{n-1})} \leq \lim_{\varepsilon^n \rightarrow 0} \int_u^{u+h} \bar{c}_R d\sigma = \bar{c}_R h. \quad (6.6)$$

From (6.4), (6.5), (6.6), we can deduce that

$$\left\| \tilde{\varphi}(u+h) - \tilde{\varphi}(u) \right\|_{\mathcal{H}_{m',1}([0;R] \times \mathbb{T}^{n-1})} \leq (R^{\frac{3}{2}} + 1) \bar{c}_R h.$$

It means that $\tilde{\varphi}$ is in $C^{0,1}(I, \mathcal{H}_{m',1}([0;R] \times \mathbb{T}^{n-1}))$.

But $C^{0,1}(I, \mathcal{H}_{m',1}([0;R] \times \mathbb{T}^{n-1})) \subset C^0(I, \mathcal{H}_{m',1}([0;R] \times \mathbb{T}^{n-1}))$, and as $m' > (n-1)/2$ i.e. $m > n-1$ we have $C^0(I, \mathcal{H}_{m',1}([0;R] \times \mathbb{T}^{n-1})) \subset C^0(I, C^0([0;R] \times \mathbb{T}^{n-1})) = C^0(I \times [0;R] \times \mathbb{T}^{n-1})$, which allows us to conclude that

$$\tilde{\varphi} \in C^0(I \times [0;R] \times \mathbb{T}^{n-1}).$$

Now we show that under certain conditions $\tilde{\varphi}$ is in $C^2(I \times [0;R] \times \mathbb{T}^{n-1})$. We start by getting $\frac{\partial^2}{\partial u \partial v} \tilde{\varphi}$ in $C^0(I \times [0;R] \times \mathbb{T}^{n-1})$. As \tilde{H} is continuous in all its variables, we have $(u, v, y) \mapsto \tilde{H}(\tilde{\varphi}, u, v, y)$ is in $C^0(I \times [0;R] \times \mathbb{T}^{n-1})$. So it suffices to prove that $\Delta_y \tilde{\varphi}$ is continuous. Here we introduce a lemma because we will need it later too. Its proof can be found at the end of the section.

Lemma 6.4 *If $m - |\alpha| - 2 > \frac{n-1}{2}$, $D_y^\alpha \tilde{\varphi}$ is in $C^0(I \times [0; R] \times \mathbb{T}^{n-1})$.*

We apply this lemma to Δ_y and finally, we obtain that if $m > \max(n - 1, \frac{n-1}{2} + 4)$ $\tilde{H}(\tilde{\varphi}) + \Delta_y \tilde{\varphi}$ is in $C^0(I \times [0; R] \times \mathbb{T}^{n-1})$. Now by the equality (6.3), we get

$$\frac{\partial^2}{\partial u \partial v} \tilde{\varphi} \in C^0(I \times [0; R] \times \mathbb{T}^{n-1}). \quad (6.7)$$

Then we show that $\tilde{\varphi}$ is in $C^2(I \times [0; R] \times \mathbb{T}^{n-1})$. First we can deduce from the result above that $\frac{\partial}{\partial v} \tilde{\varphi}$ is continuous in all its variables. Indeed

$$\begin{aligned} \frac{\partial}{\partial v} \tilde{\varphi}(u, v, y) &= \frac{\partial}{\partial v} \tilde{\varphi}(0, v, y) + \int_0^u \frac{\partial^2}{\partial u \partial v} \tilde{\varphi}(s, v, y) ds \\ &= \frac{\partial}{\partial v} \tilde{\varphi}_-(v, y) + \int_0^u \frac{\partial^2}{\partial u \partial v} \tilde{\varphi}(s, v, y) ds. \end{aligned} \quad (6.8)$$

By the definition of $\tilde{\varphi}_-$ we see that $\frac{\partial}{\partial v} \tilde{\varphi}_-(v, y) = \frac{\partial}{\partial v} \varphi_-(v, y) - \frac{\partial}{\partial v} \varphi(0, 0, y) = \frac{\partial}{\partial v} \varphi_-(v, y) - \frac{\partial}{\partial v} \varphi_-(0, y)$. As φ_- is C^{m+4} , we get

$$\frac{\partial}{\partial v} \tilde{\varphi} \in C^0(I \times [0; R] \times \mathbb{T}^{n-1}).$$

Now by this continuity of $\frac{\partial}{\partial v} \tilde{\varphi}$ we can write that

$$\begin{aligned} \tilde{\varphi}(u, v, y) &= \tilde{\varphi}(u, 0, y) + \int_0^v \frac{\partial}{\partial v} \tilde{\varphi}(u, s, y) ds \\ &= \int_0^v \frac{\partial}{\partial v} \tilde{\varphi}(u, s, y) ds. \end{aligned} \quad (6.9)$$

We differentiate in u and with (6.7), we get

$$\frac{\partial}{\partial u} \tilde{\varphi}(u, v, y) = \int_0^v \frac{\partial^2}{\partial u \partial v} \tilde{\varphi}(u, s, y) ds. \quad (6.10)$$

So

$$\frac{\partial}{\partial u} \tilde{\varphi} \in C^0(I \times [0; R] \times \mathbb{T}^{n-1}).$$

If we differentiate this equality in v , we obtain

$$\frac{\partial^2}{\partial v \partial u} \tilde{\varphi} = \frac{\partial^2}{\partial u \partial v} \tilde{\varphi} \in C^0(I \times [0; R] \times \mathbb{T}^{n-1}). \quad (6.11)$$

For derivatives in y_i of first and second order we just have to apply the lemma 6.4.

We differentiate (6.10) in y_i and as $\tilde{\varphi}$ satisfies the equation (6.3), it gives

$$\frac{\partial^2}{\partial y_i \partial u} \tilde{\varphi} = \frac{\partial}{\partial y_i} \int_0^v \tilde{H}(\tilde{\varphi}, u, s, y) + \Delta_y \tilde{\varphi}(u, s, y) ds. \quad (6.12)$$

If $\frac{\partial}{\partial y_i} \tilde{H}$ and $\frac{\partial}{\partial \theta} \tilde{H}$ are continuous in all their variables that it is the case by the assumptions on \tilde{H} , and if $\frac{\partial}{\partial y_i} \tilde{\varphi}$ is continuous in all its variables that it is the case if $m > \max(n-1, \frac{n-1}{2} + 5)$, we have $\frac{\partial}{\partial y_i} (\tilde{H}(\tilde{\varphi}, u, s, y) + \Delta_y \tilde{\varphi}(u, s, y)) = (\frac{\partial}{\partial y_i} \tilde{H})(\tilde{\varphi}, u, s, y) + (\frac{\partial}{\partial \theta} \tilde{H})(\tilde{\varphi}, u, s, y) \frac{\partial}{\partial y_i} \tilde{\varphi} + \frac{\partial}{\partial y_i} \Delta_y \tilde{\varphi}(u, s, y)$ continuous in all its variables. So we can commute \int_0^v and $\frac{\partial}{\partial y_i}$ and conclude that

$$\frac{\partial^2}{\partial y_i \partial u} \tilde{\varphi} \in C^0(I \times [0; R] \times \mathbb{T}^{n-1}).$$

By the continuity of $\frac{\partial}{\partial u} \tilde{\varphi}$ we can write

$$\begin{aligned} \tilde{\varphi}(u, v, y) &= \tilde{\varphi}(0, v, y) + \int_0^u \frac{\partial}{\partial u} \tilde{\varphi}(s, v, y) ds \\ &= \tilde{\varphi}_-(v, y) + \int_0^u \frac{\partial}{\partial u} \tilde{\varphi}(s, v, y) ds. \end{aligned}$$

As we have shown that $\frac{\partial^2}{\partial y_i \partial u} \tilde{\varphi}$ is continuous, we have

$$\frac{\partial}{\partial y_i} \tilde{\varphi}(u, v, y) = \frac{\partial}{\partial y_i} \tilde{\varphi}_-(v, y) + \int_0^u \frac{\partial^2}{\partial y_i \partial u} \tilde{\varphi}(s, v, y) ds. \quad (6.13)$$

We differentiate this equality in u , thus

$$\frac{\partial^2}{\partial u \partial y_i} \tilde{\varphi} = \frac{\partial^2}{\partial y_i \partial u} \tilde{\varphi} \in C^0(I \times [0; R] \times \mathbb{T}^{n-1}).$$

For $\frac{\partial^2}{\partial y_i \partial v} \tilde{\varphi}$ we differentiate (6.8) in y_i and as we have done for $\frac{\partial^2}{\partial y_i \partial u} \tilde{\varphi}$ we obtain that if $m > \max(n-1, \frac{n-1}{2} + 5)$

$$\frac{\partial^2}{\partial y_i \partial v} \tilde{\varphi} \in C^0(I \times [0; R] \times \mathbb{T}^{n-1}).$$

Now we differentiate the equality (6.9) first in y_i , then in v , hence

$$\frac{\partial^2}{\partial v \partial y_i} \tilde{\varphi} = \frac{\partial^2}{\partial y_i \partial v} \tilde{\varphi} \in C^0(I \times [0; R] \times \mathbb{T}^{n-1}).$$

It remains to show that $\frac{\partial^2}{\partial u^2}\tilde{\varphi}$ and $\frac{\partial^2}{\partial v^2}\tilde{\varphi}$ are continuous. For this we will see that we need the continuity of $\frac{\partial^2}{\partial y_i^2}\Delta_y\tilde{\varphi}$ and so we must take $m > \max(n-1, \frac{n-1}{2} + 6)$. We start by differentiating in u the equality (6.10) and as $\tilde{\varphi}$ satisfies the equation (6.3), we obtain

$$\frac{\partial^2}{\partial u^2}\tilde{\varphi} = \frac{\partial}{\partial u} \left(\int_0^v \tilde{H}(\tilde{\varphi}, u, s, y) + \Delta_y\tilde{\varphi}(u, s, y) ds \right).$$

We notice that $\frac{\partial}{\partial u}(\tilde{H}(\tilde{\varphi}, u, s, y) + \Delta_y\tilde{\varphi}(u, s, y)) = (\frac{\partial}{\partial u}\tilde{H})(\tilde{\varphi}, u, s, y) + (\frac{\partial}{\partial \theta}\tilde{H})(\tilde{\varphi}, u, s, y)\frac{\partial}{\partial u}\tilde{\varphi} + \frac{\partial}{\partial u}\Delta_y\tilde{\varphi}(u, s, y)$. The both first terms of the right member are continuous by the assumptions on \tilde{H} and the results above. For $\frac{\partial}{\partial u}\Delta_y\tilde{\varphi}$ we look at $\frac{\partial^3}{\partial y_i^2\partial u}\tilde{\varphi}$. If $m > \max(n-1, \frac{n-1}{2} + 6)$, $\frac{\partial^2}{\partial y_i^2}\Delta_y\tilde{\varphi}$ is continuous and by the assumptions on \tilde{H} , we have the continuity of

$$\begin{aligned} \frac{\partial^2}{\partial y_i^2}(\tilde{H}(\tilde{\varphi}, u, s, y) + \Delta_y\tilde{\varphi}(u, s, y)) &= (\frac{\partial^2}{\partial y_i^2}\tilde{H})(\tilde{\varphi}, u, s, y) + (\frac{\partial^2}{\partial \theta\partial y_i}\tilde{H})(\tilde{\varphi}, u, s, y)\frac{\partial}{\partial y_i}\tilde{\varphi} \\ &\quad + (\frac{\partial^2}{\partial y_i\partial \theta}\tilde{H})(\tilde{\varphi}, u, s, y)\frac{\partial}{\partial y_i}\tilde{\varphi} + (\frac{\partial^2}{\partial \theta^2}\tilde{H})(\tilde{\varphi}, u, s, y)(\frac{\partial}{\partial y_i}\tilde{\varphi})^2 \\ &\quad + (\frac{\partial}{\partial \theta}\tilde{H})(\tilde{\varphi}, u, s, y)\frac{\partial^2}{\partial y_i^2}\tilde{\varphi} + \frac{\partial^2}{\partial y_i^2}\Delta_y\tilde{\varphi}(u, s, y). \end{aligned}$$

So by differentiating the equality (6.12) in y_i , we get

$$\frac{\partial^3}{\partial y_i^2\partial u}\tilde{\varphi} = \int_0^v \frac{\partial^2}{\partial y_i^2}(\tilde{H}(\tilde{\varphi}, u, s, y) + \Delta_y\tilde{\varphi}(u, s, y)) ds.$$

Hence

$$\frac{\partial^3}{\partial y_i^2\partial u}\tilde{\varphi} \in C^0(I \times [0; R] \times \mathbb{T}^{m-1}).$$

Now we differentiate the equality (6.13) first in y_i , then in u , and so we obtain

$$\frac{\partial^3}{\partial u\partial y_i^2}\tilde{\varphi} = \frac{\partial^3}{\partial y_i^2\partial u}\tilde{\varphi} \in C^0(I \times [0; R] \times \mathbb{T}^{m-1}).$$

It suffices to add on y_i to get the continuity of $\frac{\partial}{\partial u}\Delta_y\tilde{\varphi}$. Finally we can say that if $m > \max(n-1, \frac{n-1}{2} + 6)$,

$$\frac{\partial^2}{\partial u^2}\tilde{\varphi} \in C^0(I \times [0; R] \times \mathbb{T}^{m-1}).$$

We proceed similarly for $\frac{\partial^2}{\partial v^2}\tilde{\varphi}$ (we have supplementary terms, $\frac{\partial^2}{\partial v^2}\tilde{\varphi}_-$ and $\frac{\partial^3}{\partial y_i^2\partial v}\tilde{\varphi}_-$ which are continuous by assumptions on $\tilde{\varphi}_-$). If $m > \max(n-1, \frac{n-1}{2} + 6)$,

$$\frac{\partial^2}{\partial v^2}\tilde{\varphi} \in C^0(I \times [0; R] \times \mathbb{T}^{m-1}).$$

At the end, all the results above allow us to conclude that if $m > \max(n-1, \frac{n-1}{2} + 6)$,

$$\tilde{\varphi} \in C^2(I \times [0; R] \times \mathbb{T}^{n-1}).$$

For the class C^l we follow the same method and so we take $m > \max(n-1, \frac{n-1}{2} + l + 4)$, but we need also greater assumptions on \tilde{H} and so on H , that is to say for any $0 \leq a \leq l-1$, $0 \leq b \leq l-1$, $0 \leq \gamma + |\mu| \leq m+1$, $D_u^a D_v^b D_\theta^\gamma D_y^\mu H$ continuous in all its variables. This is equivalent to the assumptions on F: for any $0 \leq a \leq l-1$, $0 \leq b \leq l-1$, $0 \leq \gamma + |\mu| \leq m+1$, $D_t^a D_{x^1}^b D_\theta^\gamma D_y^\mu F$ is continuous in all its variables. \square

Proof of the Lemma 6.4:

In the proof of the lemma 6.1 we have seen that $\| D_y^\alpha \tilde{\varphi}_{\varepsilon^n}(u) - D_y^\alpha \tilde{\varphi}(u) \|_{\mathcal{H}_{m-|\alpha|,1}} \rightarrow 0$. So we can write

$$\begin{aligned} \| D_y^\alpha \tilde{\varphi}(u+h) - D_y^\alpha \tilde{\varphi}(u) \|_{\mathcal{H}_{m-|\alpha|-2,1}} &= \lim_{\varepsilon^n \rightarrow 0} \| D_y^\alpha \tilde{\varphi}_{\varepsilon^n}(u+h) - D_y^\alpha \tilde{\varphi}_{\varepsilon^n}(u) \|_{\mathcal{H}_{m-|\alpha|-2,1}} \\ &= \lim_{\varepsilon^n \rightarrow 0} \left\| \int_u^{u+h} D_y^\alpha \frac{\partial}{\partial u} \tilde{\varphi}_{\varepsilon^n}(\sigma) d\sigma \right\|_{\mathcal{H}_{m-|\alpha|-2,1}} \end{aligned}$$

because of the continuity in all its variables (u, v, y) of $\frac{\partial}{\partial u} D_y^\alpha \tilde{\varphi}_{\varepsilon^n}$. Hence by lemma 6.3 and by taking the limit, we obtain

$$\| D_y^\alpha \tilde{\varphi}(u+h) - D_y^\alpha \tilde{\varphi}(u) \|_{\mathcal{H}_{m-|\alpha|-2,1}} \leq \lim_{\varepsilon^n \rightarrow 0} \int_u^{u+h} \| D_y^\alpha \frac{\partial}{\partial u} \tilde{\varphi}_{\varepsilon^n}(\sigma) \|_{\mathcal{H}_{m-|\alpha|-2,1}} d\sigma.$$

But by the continuity of $\frac{\partial}{\partial v} D_y^\alpha \frac{\partial}{\partial u} \tilde{\varphi}_{\varepsilon^n}$ and the fact that we can commute the partial derivatives, we have

$$D_y^\alpha \frac{\partial}{\partial u} \tilde{\varphi}_{\varepsilon^n}(\sigma, v, y) = D_y^\alpha \frac{\partial}{\partial u} \tilde{\varphi}_{\varepsilon^n}(\sigma, 0, y) + \int_0^v D_y^\alpha \frac{\partial^2}{\partial u \partial v} \tilde{\varphi}_{\varepsilon^n}(\sigma, s, y) ds.$$

The first term of right member vanishes (indeed the third equation of the problem (4.1) gives that $\tilde{\varphi}_{\varepsilon^n}(u, 0, y)$ vanishes, so by differentiating in u and in y , it also vanishes). By using the second equation of the problem (4.1) and the result (5.5), we get

$$D_y^\alpha \frac{\partial}{\partial u} \tilde{\varphi}_{\varepsilon^n}(\sigma, v, y) = \int_0^v \hat{J}_{\varepsilon^n} D_y^\alpha \tilde{H}(\tilde{\varphi}_{\varepsilon^n}, \sigma, s, y) + (D_y^\alpha \Delta_y) \tilde{\varphi}_{\varepsilon^n}(\sigma, s, y) ds.$$

Now, we take the norm $\mathcal{H}_{m-|\alpha|-2,1}$ of the both members and we apply lemma 6.2 on the right one, so

$$\begin{aligned} \| D_y^\alpha \frac{\partial}{\partial u} \tilde{\varphi}_{\varepsilon^n}(\sigma) \|_{\mathcal{H}_{m-|\alpha|-2,1}} &\leq (R^{\frac{3}{2}} + 1) \| \hat{J}_{\varepsilon^n} \Delta_y \tilde{H}(\tilde{\varphi}_{\varepsilon^n}(\sigma), \sigma) + (D_y^\alpha \Delta_y) \tilde{\varphi}_{\varepsilon^n}(\sigma) \|_{\mathcal{H}_{m-|\alpha|-2,0}} \\ &\leq (R^{\frac{3}{2}} + 1) (\| \Delta_y \tilde{H}(\tilde{\varphi}_{\varepsilon^n}(\sigma), \sigma) \|_{\mathcal{H}_{m-|\alpha|-2,0}} + \| \tilde{\varphi}_{\varepsilon^n}(\sigma) \|_{\mathcal{H}_{m,0}}) \end{aligned}$$

Then by the assumptions on the regularity of \tilde{H} , we obtain

$$\begin{aligned} \| D_y^\alpha \frac{\partial}{\partial u} \tilde{\varphi}_{\varepsilon^n}(\sigma) \|_{\mathcal{H}_{m-|\alpha|-2,1}} &\leq (R^{\frac{3}{2}} + 1)(c(\| \tilde{\varphi}_{\varepsilon^n}(\sigma) \|_{L^\infty}, \sigma)(1 + \| \tilde{\varphi}_{\varepsilon^n}(\sigma) \|_{\mathcal{H}_{m-|\alpha|,0}}) + \| \tilde{\varphi}_{\varepsilon^n}(\sigma) \|_{\mathcal{H}_{m,0}}) \\ &\leq c_R \end{aligned}$$

because $\| \tilde{\varphi}_{\varepsilon^n}(\sigma) \|_{L^\infty}, \sigma, \| \tilde{\varphi}_{\varepsilon^n}(\sigma) \|_{\mathcal{H}_{m-|\alpha|,0}}, \| \tilde{\varphi}_{\varepsilon^n}(\sigma) \|_{\mathcal{H}_{m,0}}$ are bounded on I .
Hence

$$\| D_y^\alpha \tilde{\varphi}(u+h) - D_y^\alpha \tilde{\varphi}(u) \|_{\mathcal{H}_{m-|\alpha|-2,1}} \leq \lim_{\varepsilon^n \rightarrow 0} \int_u^{u+h} c_R d\sigma = c_R h$$

It means that $D_y^\alpha \tilde{\varphi}$ is in $C^{0,1}(I, \mathcal{H}_{m-|\alpha|-2,1}([0; R] \times \mathbb{T}^{n-1}))$.

But $C^{0,1}(I, \mathcal{H}_{m-|\alpha|-2,1}([0; R] \times \mathbb{T}^{n-1})) \subset C^0(I, \mathcal{H}_{m-|\alpha|-2,1}([0; R] \times \mathbb{T}^{n-1}))$, and as $m - |\alpha| - 2 > (n - 1)/2$ we have $C^0(I, \mathcal{H}_{m-|\alpha|-2,1}([0; R] \times \mathbb{T}^{n-1})) \subset C^0(I, C^0([0; R] \times \mathbb{T}^{n-1})) = C^0(I \times [0; R] \times \mathbb{T}^{n-1})$, which allows us to conclude that

$$D_y^\alpha \tilde{\varphi} \in C^0(I \times [0; R] \times \mathbb{T}^{n-1}).$$

△

7 Existence and uniqueness of the solution of the problem (1.1)

7.1 Existence of φ

We can show now the following theorem

Theorem 7.1 *If $m > \max(n - 1, \frac{n-1}{2} + 4)$, and*

(i) $F : (\theta, t, x^1, y) \mapsto F(\theta, t, x^1, y)$ satisfies that for any $0 \leq a \leq 1, 0 \leq b \leq 1, 0 \leq \gamma + |\mu| \leq m + 1$, $D_t^a D_{x^1}^b D_\theta^\gamma D_y^\mu F$ is continuous in all its variables

(ii) φ_+, φ_- are of class H^{m+5} , and φ_+, φ_- satisfy the corner condition:
 $\varphi_+(0, y) = \varphi_-(0, y)$.

(iii) There exists a real $T > 0$ such that F, φ_+, φ_- are T -periodic in each y_i .

then for all real $R > 0$, there exist some reals $R' > 0$ and $R'' > 0$ such that there exists a solution φ for the problem (1.1) in the domain $\Omega = \{0 \leq t - x^1 \leq R, 0 \leq t + x^1 \leq R', (x^2, \dots, x^n) \in \mathbb{T}^{n-1}\} \cup \{0 \leq t + x^1 \leq R, 0 \leq t - x^1 \leq R'', (x^2, \dots, x^n) \in \mathbb{T}^{n-1}\}$ where \mathbb{T}^{n-1} is the torus of dimension $n - 1$ and of length T in each direction, and this solution is in $C^0(\Omega)$.

Moreover, for all $l \geq 2$, if $m > \max(n - 1, \frac{n-1}{2} + 4 + l)$, and if for any $0 \leq a \leq l - 1, 0 \leq b \leq l - 1, 0 \leq \gamma + |\mu| \leq m + 1$, $D_t^a D_{x^1}^b D_\theta^\gamma D_y^\mu F$ is continuous in all its variables, then φ is in $C^l(\Omega)$.

Proof of the theorem 7.1:

In the first step we prove the existence of a solution φ satisfying equation (3.1), then in the second one we study its regularity , after that we show that we can do the same along N_+ .

7.1.1 Existence of a solution φ

We set $I = [0; R']$ and

$$\varphi(u, v, y) = \tilde{\varphi}(u, v, y) + \varphi_+(u, y) + \left(\frac{\partial}{\partial v}\varphi_-(0, y) + \int_0^u H(\varphi_+(s, y), s, 0, y) + \Delta_y\varphi_+(s, y)ds\right)v \quad (7.1)$$

We notice that

$$\varphi(u, 0, y) = \tilde{\varphi}(u, 0, y) + \varphi_+(u, y) = \varphi_+(u, y)$$

and

$$\begin{aligned} \varphi(0, v, y) &= \tilde{\varphi}(0, v, y) + \varphi_+(0, y) + \left(\frac{\partial}{\partial v}\varphi_-(0, y)\right)v \\ &= \tilde{\varphi}_-(v, y) + \varphi_+(0, y) + \left(\frac{\partial}{\partial v}\varphi_-(0, y)\right)v \\ &= \varphi_-(v, y) \end{aligned}$$

by the definition of $\tilde{\varphi}_-$ given in (3.4).

Now as we know that

$$\frac{\partial^2}{\partial u \partial v} \tilde{\varphi} = \tilde{H}(\tilde{\varphi}, u, v, y) + \Delta_y \tilde{\varphi}$$

and by the regularity of the functions H, φ_+, φ_- , we obtain

$$\frac{\partial^2}{\partial u \partial v} \varphi = \tilde{H}(\tilde{\varphi}, u, v, y) + \Delta_y \tilde{\varphi} + H(\varphi_+(u, y), u, 0, y) + \Delta_y \varphi_+(u, y).$$

By the definition of \tilde{H} given in (3.2) we get

$$\frac{\partial^2}{\partial u \partial v} \varphi(u, v, y) = H(\varphi, u, v, y) + \Delta_y \varphi(u, v, y).$$

To obtain φ solution of the problem (1.1) it remains to show that $\frac{\partial^2}{\partial u \partial v} \varphi = \frac{\partial^2}{\partial v \partial u} \varphi$. we differentiate the equality (7.1) first in u , then in v , hence

$$\frac{\partial^2}{\partial v \partial u} \varphi = \frac{\partial^2}{\partial v \partial u} \tilde{\varphi} + H(\varphi_+(u, y), u, 0, y) + \Delta_y \varphi_+(u, y).$$

But we know (see (6.11)) that if $m > \max(n - 1, \frac{n-1}{2} + 4)$,

$$\begin{aligned}\frac{\partial^2}{\partial v \partial u} \tilde{\varphi} &= \frac{\partial^2}{\partial u \partial v} \tilde{\varphi} \\ &= \tilde{H}(\tilde{\varphi}, u, v, y) + \Delta_y \tilde{\varphi}.\end{aligned}$$

Thus we have

$$\frac{\partial^2}{\partial u \partial v} \varphi = \frac{\partial^2}{\partial v \partial u} \varphi$$

which gives that φ is a solution of the problem (1.1).

7.1.2 Regularity of φ

To study the regularity of φ it suffices to study the regularity of $\delta(\varphi_+, \varphi_-) = \varphi_+(u, y) + (\frac{\partial}{\partial v} \varphi_-(0, y) + \int_0^u H(\varphi_+(s, y), s, 0, y) + \Delta_y \varphi_+(s, y) ds)v$ because we have already results about the regularity of $\tilde{\varphi}$ by the proposition (6.1).

We start by the derivative of first order of $\delta(\varphi_+, \varphi_-)$. We have

$$\frac{\partial}{\partial u} \delta(\varphi_+, \varphi_-) = \frac{\partial}{\partial u} \varphi_+(u, y) + (H(\varphi_+(u, y), u, 0, y) + \Delta_y \varphi_+(u, y) ds)v$$

and

$$\frac{\partial}{\partial v} \delta(\varphi_+, \varphi_-) = \frac{\partial}{\partial v} \varphi_-(0, y) + \int_0^u H(\varphi_+(s, y), s, 0, y) + \Delta_y \varphi_+(s, y) ds$$

which are in $C^0(I \times [0; R] \times \mathbb{T}^{n-1})$ by the assumptions on the functions H, φ_+, φ_- . At least, these assumptions on the functions H, φ_+, φ_- allow us to commute \int_0^u and $\frac{\partial}{\partial y_i}$, so we can write

$$\begin{aligned}\frac{\partial}{\partial y_i} \delta(\varphi_+, \varphi_-) &= \frac{\partial}{\partial y_i} \varphi_+(u, y) + (\frac{\partial^2}{\partial y_i \partial v} \varphi_-(0, y) + \int_0^u (\frac{\partial}{\partial \theta} H)(\varphi_+(s, y), s, 0, y) \frac{\partial}{\partial y_i} \varphi_+(s, y) \\ &\quad + (\frac{\partial}{\partial y_i} \tilde{H})(\varphi_+(s, y), s, 0, y) + \frac{\partial}{\partial y_i} \Delta_y \varphi_+(s, y) ds)v.\end{aligned}$$

So $\frac{\partial}{\partial y_i} \delta(\varphi_+, \varphi_-)$ is in $C^0(I \times [0; R] \times \mathbb{T}^{n-1})$.

For the derivative of second order of $\delta(\varphi_+, \varphi_-)$ we get similarly

$$\begin{aligned}\frac{\partial^2}{\partial y_i \partial v} \delta(\varphi_+, \varphi_-) &= \frac{\partial^2}{\partial y_i \partial v} \varphi_-(0, y) + \int_0^u (\frac{\partial}{\partial \theta} H)(\varphi_+(s, y), s, 0, y) \frac{\partial}{\partial y_i} \varphi_+(s, y) \\ &\quad + (\frac{\partial}{\partial y_i} \tilde{H})(\varphi_+(s, y), s, 0, y) + \frac{\partial}{\partial y_i} \Delta_y \varphi_+(s, y) ds \\ &= \frac{\partial^2}{\partial v \partial y_i} \delta(\varphi_+, \varphi_-).\end{aligned}$$

$$\begin{aligned}
\frac{\partial^2}{\partial y_i \partial u} \delta(\varphi_+, \varphi_-) &= \frac{\partial^2}{\partial y_i \partial u} \varphi_+(u, y) + \left(\left(\frac{\partial}{\partial \theta} H \right) (\varphi_+(s, y), s, 0, y) \frac{\partial}{\partial y_i} \varphi_+(s, y) \right. \\
&\quad \left. + \left(\frac{\partial}{\partial y_i} \tilde{H} \right) (\varphi_+(s, y), s, 0, y) + \frac{\partial}{\partial y_i} \Delta_y \varphi_+(s, y) \right) v \\
&= \frac{\partial^2}{\partial u \partial y_i} \delta(\varphi_+, \varphi_-).
\end{aligned}$$

$$\begin{aligned}
\frac{\partial^2}{\partial u \partial v} \delta(\varphi_+, \varphi_-) &= H(\varphi_+(u, y), u, 0, y) + \Delta_y \varphi_+(u, y) \\
&= \frac{\partial^2}{\partial v \partial u} \delta(\varphi_+, \varphi_-)
\end{aligned}$$

$$\begin{aligned}
\frac{\partial^2}{\partial u^2} \delta(\varphi_+, \varphi_-) &= \frac{\partial^2}{\partial u^2} \varphi_+(u, y) + \left(\left(\frac{\partial}{\partial \theta} H \right) (\varphi_+(u, y), u, 0, y) \frac{\partial}{\partial u} \varphi_+(u, y) \right. \\
&\quad \left. + \left(\frac{\partial}{\partial u} \tilde{H} \right) (\varphi_+(u, y), u, 0, y) + \frac{\partial}{\partial u} \Delta_y \varphi_+(u, y) \right) v.
\end{aligned}$$

We can see that they are all in $C^0(I \times [0; R] \times \mathbb{T}^{n-1})$. Now

$$\frac{\partial^2}{\partial v^2} \delta(\varphi_+, \varphi_-) = 0.$$

$$\begin{aligned}
\frac{\partial^2}{\partial y_i^2} \delta(\varphi_+, \varphi_-) &= \frac{\partial^2}{\partial y_i^2} \varphi_+(u, y) + \left(\frac{\partial^3}{\partial y_i^2 \partial v} \varphi_-(0, y) + \int_0^u \left(\frac{\partial^2}{\partial \theta^2} H \right) (\varphi_+(s, y), s, 0, y) \frac{\partial}{\partial y_i} \varphi_+(s, y) \right. \\
&\quad \left. + \left(\frac{\partial^2}{\partial y_i \partial \theta} H \right) (\varphi_+(s, y), s, 0, y) \frac{\partial}{\partial y_i} \varphi_+(s, y) + \left(\frac{\partial}{\partial \theta} H \right) (\varphi_+(s, y), s, 0, y) \frac{\partial^2}{\partial y_i^2} \varphi_+(s, y) \right. \\
&\quad \left. + \left(\frac{\partial^2}{\partial \theta \partial y_i} H \right) (\varphi_+(s, y), s, 0, y) \frac{\partial}{\partial y_i} \varphi_+(s, y) + \left(\frac{\partial^2}{\partial y_i^2} \tilde{H} \right) (\varphi_+(s, y), s, 0, y) \right. \\
&\quad \left. + \frac{\partial^2}{\partial y_i^2} \Delta_y \varphi_+(s, y) \right) ds) v.
\end{aligned}$$

So $\frac{\partial^2}{\partial y_i^2} \delta(\varphi_+, \varphi_-)$ is also in $C^0(I \times [0; R] \times \mathbb{T}^{n-1})$.

Thus we can conclude without adding assumptions, that if $m > \max(n-1, \frac{n-1}{2} + 6)$ the solution φ is in $C^2(I \times [0; R] \times \mathbb{T}^{n-1})$. We come back to the variables t and x^1 by the fact that $t = u + v$ and $x^1 = v - u$, so we get the same regularity.

We proceed similarly for higher derivatives and we see that the assumptions necessarily to obtain φ of class C^l are not stronger than those necessarily to obtain $\tilde{\varphi}$ of class C^l .

7.1.3 Conclusion

So we have finally the existence of the solution of the problem (1.1) in a one-sided future neighborhood of a compact $([0; R] \times \mathbb{T}^{n-1}) \subset N_-$ where $[0; R]$ is as large as we want.

To obtain the existence of the solution of the problem (1.1) in a future timelike neighborhood of a compact $([0; R] \times \mathbb{T}^{n-1}) \subset N_+$ it suffices to exchange the role of u and v and to apply the same method.

7.2 Uniqueness of φ

For the uniqueness of the solution φ we take a piece of time to examine the geometry of the problem.

Let $\tau = \frac{R}{\sqrt{2}}$, $\tilde{y} \in \mathbb{R}^{n-1}$ and P the point of coordinates $(\tau + R', -\tau + R', \tilde{y})$ in \mathbb{R}^{n+1} . We consider J_P^- a part of the past light cone issued of P , precisely

$$J_P^- = \{(t, x^1, y) \in \mathbb{R}^{n+1} / 0 \leq t \leq \tau + R', \quad (t - (\tau + R'))^2 = (x^1 - (-\tau + R'))^2 + |y - \tilde{y}|^2\}.$$

We recall that N_+ is the hypersurface $N_+ = \{(t, x^1, y) \in \mathbb{R}^{n+1} / t + x^1 = 0, t \geq 0\}$. It is easy to see that $J_P^- \cap N_+$ is a part of the parabola \mathcal{P} of top $P'(\tau, -\tau, \tilde{y})$, $\mathcal{P} = \{(t, x^1, y) \in \mathbb{R}^{n+1} / |y - \tilde{y}|^2 = 4R'(x^1 + \tau)\}$. We call \mathcal{U}_P the set J_P^- intersected with the future of N_+ and the future of $N_- = \{(t, x^1, y) \in \mathbb{R}^{n+1} / t - x^1 = 0, t \geq 0\}$. We can visualize the situation by the following figure .

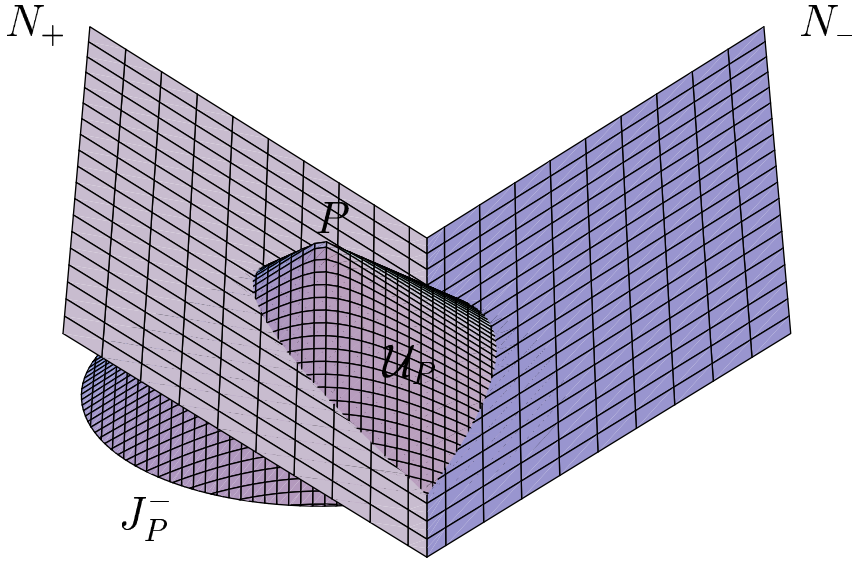

We're going to prove the uniqueness of the solution of the problem (1.1) found before, in \mathcal{U}_P . Then we call $\mathcal{U}_{P,\tau'}$ the set \mathcal{U}_P intersected with the past of the hypersurface $\{(t, x^1, y) \in \mathbb{R}^{n+1} / t = \tau'\}$ which we denote simply $\{t = \tau'\}$.

Let φ_1, φ_2 be two solutions of the problem (1.1). We set $\varphi = \varphi_1 - \varphi_2$, so we have

$$\begin{cases} \square\varphi = F(\varphi_1, t, x^1, y) - F(\varphi_2, t, x^1, y) \\ \varphi|_{N_+} = 0 \\ \varphi|_{N_-} = 0 \end{cases}$$

As $\frac{\partial F}{\partial \theta}$ is continuous (recall that θ is the first variable of F) and φ_1, φ_2 bounded (indeed $(u, v, y) \mapsto \varphi_1(u, v, y)$ and $(u, v, y) \mapsto \varphi_2(u, v, y)$ are C^2 so continuous on $[0; R] \times [0; R'] \times \mathbb{T}^{n-1}$), we can write that

$$\begin{aligned} |F(\varphi_1(t, x^1, y), t, x^1, y) - F(\varphi_2(t, x^1, y), t, x^1, y)| &\leq \| \varphi_1 - \varphi_2 \| \max_{0 \leq s \leq 1} \left\| \frac{\partial F}{\partial \theta}((1-s)\varphi_1 + s\varphi_2) \right\| \\ &\leq c \| \varphi \| . \end{aligned}$$

Furthermore

$$|\square\varphi| \leq c \| \varphi \| . \quad (7.2)$$

To prove that φ vanishes in \mathcal{U}_P , we first estimate for any $0 \leq \tau' \leq \tau + R'$ some energy $E(\tau')$ of φ , namely

$$\begin{aligned} E(\tau') &= \int_{\mathcal{U}_{P, \tau'} \cap \{t=\tau'\}} \frac{1}{2} (\varphi^2 + |\nabla\varphi|^2) dS \\ \text{where } |\nabla\varphi|^2 &= \left(\frac{\partial\varphi}{\partial t}\right)^2 + \left(\frac{\partial\varphi}{\partial x^1}\right)^2 + \sum_{i=1}^{n-1} \left(\frac{\partial\varphi}{\partial y_i}\right)^2 . \end{aligned}$$

Then we show that $E(\tau')$ vanishes for any $0 \leq \tau' \leq \tau + R'$.

For this we use some notions of physics sciences and so introduce a tensor, called tensor of impulsive energy. As it is usually denoted in differential geometry literature, we set

$$X = \sum_{\mu} X^{\mu} \partial_{\mu}$$

where $\{\partial_{\mu}\}$ is a basis of local coordinates system of dimension $n + 1$.

We denote ∇_{μ} a covariant derivative with respect to ∂_{μ} and $\nabla^{\mu} := \sum_{\nu} \eta^{\mu\nu} \nabla_{\nu}$ where η is the diagonal matrix of dimension $n + 1$ of diagonal $(-1, 1, \dots, 1)$.

Now we consider the tensor T acting on one-vector field, namely

$$\begin{aligned} T(X) &= \sum_{\mu, \nu} T^{\mu}_{\nu} X^{\nu} \partial_{\mu} \\ \text{with } T^{\mu}_{\nu} &= \nabla^{\mu} \varphi \nabla_{\nu} \varphi - \frac{1}{2} \left(\left(\sum_{\alpha} \nabla^{\alpha} \varphi \nabla_{\alpha} \varphi \right) + \varphi^2 \right) \delta^{\mu}_{\nu} \end{aligned}$$

(δ^μ_ν is the Kronecker symbol i.e. δ^μ_ν vanishes if $\mu \neq \nu$ and equals to 1 if $\mu = \nu$).

Notice that for $\mu = \nu = 0$ we obtain

$$\begin{aligned} T^0_0 &= -(\partial_t \varphi)^2 - \frac{1}{2}(-(\partial_t \varphi)^2 + (\partial_{x_1} \varphi)^2 + \dots + (\partial_{x_n} \varphi)^2 + \varphi^2) \\ &= -\frac{1}{2}((\partial_t \varphi)^2 + (\partial_{x_1} \varphi)^2 + \dots + (\partial_{x_n} \varphi)^2 + \varphi^2) \\ &= -\frac{1}{2}(\varphi^2 + |\nabla \varphi|^2). \end{aligned}$$

By the theorem of Stokes we know that, for every open set Ω ,

$$\int_{\partial\Omega} T(X) dS = \int_{\Omega} \text{div}(T(X)) dV$$

where dS is the infinitesimal element of surface on $\partial\Omega$, more precisely $T(X) dS = \sum_{\mu} T^{\mu}(X) dS_{\mu}$,

dV is the infinitesimal element of volume on Ω , and as we will take a constant vector X (more precisely $X = \partial_0$), $\text{div}(T(X)) = \sum_{\mu, \nu} \nabla_{\mu}(T^{\mu}_{\nu} X^{\nu})$.

Therefore we calculate $\nabla_{\mu} T^{\mu}_{\nu}$.

$$\begin{aligned} \nabla_{\mu} T^{\mu}_{\nu} &= \nabla_{\mu}(\nabla^{\mu} \varphi \nabla_{\nu} \varphi - \frac{1}{2}((\sum_{\alpha} \nabla^{\alpha} \varphi \nabla_{\alpha} \varphi) + \varphi^2) \delta^{\mu}_{\nu}) \\ &= (\nabla_{\mu} \nabla^{\mu} \varphi) \nabla_{\nu} \varphi + \nabla^{\mu} \varphi (\nabla_{\mu} \nabla_{\nu} \varphi) - \frac{1}{2} \delta^{\mu}_{\nu} \nabla_{\mu} ((\sum_{\alpha} \nabla^{\alpha} \varphi \nabla_{\alpha} \varphi) + \varphi^2). \end{aligned}$$

Now we sum on μ :

$$\sum_{\mu} \nabla_{\mu} T^{\mu}_{\nu} = \sum_{\mu} (\nabla_{\mu} \nabla^{\mu} \varphi) \nabla_{\nu} \varphi + \sum_{\mu} \nabla^{\mu} \varphi (\nabla_{\mu} \nabla_{\nu} \varphi) - \frac{1}{2} \nabla_{\nu} (\sum_{\alpha} \nabla^{\alpha} \varphi \nabla_{\alpha} \varphi) - \varphi \nabla_{\nu} \varphi.$$

For the first term of the right member of the equality above, we can notice that

$$(\sum_{\mu} \nabla_{\mu} \nabla^{\mu} \varphi) \nabla_{\nu} \varphi = (\sum_{\mu, \alpha} \eta^{\mu\alpha} \nabla_{\mu} \nabla_{\alpha} \varphi) \nabla_{\nu} \varphi = \square \varphi \nabla_{\nu} \varphi.$$

For the second and third one, we have

$$\sum_{\mu} \nabla^{\mu} \varphi (\nabla_{\mu} \nabla_{\nu} \varphi) = \sum_{\mu, \alpha} \eta^{\mu\alpha} \nabla_{\alpha} \varphi (\nabla_{\mu} \nabla_{\nu} \varphi)$$

and

$$-\frac{1}{2} \nabla_{\nu} (\sum_{\alpha} \nabla^{\alpha} \varphi \nabla_{\alpha} \varphi) = -\frac{1}{2} \sum_{\mu, \alpha} (\eta^{\mu\alpha} (\nabla_{\nu} \nabla_{\mu} \varphi) \nabla_{\alpha} \varphi + \eta^{\mu\alpha} \nabla_{\mu} \varphi (\nabla_{\nu} \nabla_{\alpha} \varphi)).$$

Then if φ is of class C^2 , it is easy to see that

$$\sum_{\mu} \nabla_{\mu} T^{\mu}_{\nu} = (\square\varphi - \varphi) \nabla_{\nu} \varphi.$$

In particular if $\nu = 0$,

$$\sum_{\mu} \nabla_{\mu} T^{\mu}_0 = (\square\varphi - \varphi) \nabla_0 \varphi = (\square\varphi - \varphi) \partial_t \varphi. \quad (7.3)$$

We apply the theorem of Stokes with $\Omega = \mathcal{U}_{P,\tau'}$. By looking the intersection of $\mathcal{U}_{P,\tau'}$ with the hypersurfaces N_-, N_+ and $\{t = \tau'\}$, we can decompose $\partial\mathcal{U}_{P,\tau'}$ in four parts as it follows :

$$\partial\mathcal{U}_{P,\tau'} = (\mathcal{U}_{P,\tau'} \cap N_-) \cup (\mathcal{U}_{P,\tau'} \cap N_+) \cup (\mathcal{U}_{P,\tau'} \cap \{t = \tau'\}) \cup \mathcal{C}_{\tau'}$$

where $\mathcal{C}_{\tau'}$ is the only curved part of $\partial\mathcal{U}_{P,\tau'}$.

As φ vanishes on N_- and N_+ , when we integrate on $\partial\mathcal{U}_{P,\tau'}$ it only remains the integrals on $\mathcal{U}_{P,\tau'} \cap \{t = \tau'\}$ and on $\mathcal{C}_{\tau'}$.

For the integral on $\mathcal{C}_{\tau'}$, we integrate on characteristic hypersurface, by elementary lorentzian geometry, we know that integrate on a characteristic hypersurface is equivalent to integrate only the component in isotropic vector tangent to this characteristic hypersurface, but $\sum T_{\mu\nu} Y^{\mu} Z^{\nu} \geq 0$ when Y, Z are timelike or isotropic future directed vectors. Hence this integral is less or equal to zero.

For the integral on $\mathcal{U}_{P,\tau'} \cap \{t = \tau'\}$, as the time is constant, all the elements of surface dS_{μ} vanishes except of dS_0 .

So we obtain

$$\begin{aligned} \int_{\mathcal{U}_{P,\tau'} \cap \{t=\tau'\}} T^0_0 dS_0 &\geq \int_{\mathcal{U}_{P,\tau'}} \sum_{\mu} \nabla_{\mu} T^{\mu}_0 dV \\ E(\tau') &\leq - \int_{\mathcal{U}_{P,\tau'}} \sum_{\mu} \nabla_{\mu} T^{\mu}_0 dV. \end{aligned}$$

On another hand by using (7.3) and (7.2), we have

$$\begin{aligned} \left| \int_{\mathcal{U}_{P,\tau'}} (\nabla T)(X) dV \right| &= \left| \int_{\mathcal{U}_{P,\tau'}} (\square\varphi - \varphi) \partial_t \varphi dV \right| \\ &\leq \int_{\mathcal{U}_{P,\tau'}} c |\varphi| |\partial_t \varphi| dV \\ &\leq \frac{1}{2} c \int_{\mathcal{U}_{P,\tau'}} |\varphi|^2 + |\partial_t \varphi|^2 dV \\ &\leq \frac{1}{2} c \int_{\mathcal{U}_{P,\tau'}} |\varphi|^2 + |\nabla \varphi|^2 dV. \end{aligned}$$

By the theorem of Fubini, as $\mathcal{U}_{P,\tau'} = \bigcup_{s \in [0;\tau']} (\mathcal{U}_{P,\tau'} \cap \{t = s\})$, we get

$$\begin{aligned} \frac{1}{2}c \int_{\mathcal{U}_{P,\tau'}} |\varphi|^2 + |\nabla\varphi|^2 dV &= \frac{1}{2}c \int_0^{\tau'} \left(\int_{\mathcal{U}_{P,\tau'} \cap \{t=s\}} |\varphi|^2 + |\nabla\varphi|^2 dS \right) ds \\ &= c \int_0^{\tau'} E(s) ds. \end{aligned}$$

Finally for any $0 \leq \tau' \leq \tau + \lambda$,

$$E(\tau') \leq c \int_0^{\tau'} E(s) ds.$$

Then we set $h(t) = e^{-ct} \int_0^t E(s) ds$. We have $h'(t) = -ce^{-ct} \int_0^t E(s) ds + e^{-ct} E(t) \leq 0$ so for any $0 \leq t \leq \tau + \lambda$, $h(t) \leq h(0) = 0$, it means that for any $0 \leq t \leq \tau + \lambda$, $\int_0^t E(s) ds \leq 0$. Hence $E(t) \leq 0$ almost everywhere on $[0; \tau + \lambda]$, and as E is continuous, we can conclude that for any $0 \leq t \leq \tau + \lambda$, $E(t) = 0$. This implies that φ vanishes almost everywhere in $\mathcal{U}_{P,\tau'}$, then everywhere by continuity of φ .

Hence if the functions F, φ_+, φ_- are periodic in y , we get the uniqueness in $\bigcup_R \mathcal{V}_R$, where $\mathcal{V}_R := \{0 \leq t - x^1 \leq R, 0 \leq t + x^1 \leq R'_R, (x^2, \dots, x^n) \in \mathbb{T}^{n-1}\} \cup \{0 \leq t + x^1 \leq R, 0 \leq t - x^1 \leq R''_R, (x^2, \dots, x^n) \in \mathbb{T}^{n-1}\}$ (R'_R and R''_R are the reals found at each R see theorem 7.1). Notice that $\bigcup_R \mathcal{V}_R$ is a set of length T in each y_i with a transversal section in (u, v) which looks like a strip limited from below by $N_+ \cup N_-$, limited from above by an hyperbola, we can visualize it by the following figure.

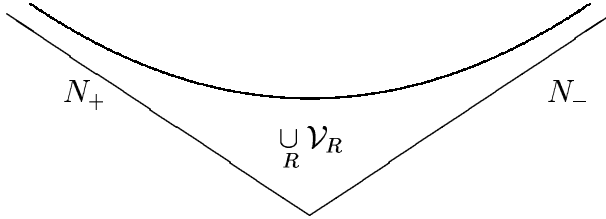

We resume all the results in the following theorem :

Theorem 7.2 *If $m > \max(n - 1, \frac{n-1}{2} + 4)$, and*

- (i) $F : (\theta, t, x^1, y) \mapsto F(\theta, t, x^1, y)$ satisfies that for any $0 \leq a \leq 1, 0 \leq b \leq 1, 0 \leq \gamma + |\mu| \leq m + 1$, $D_t^a D_{x^1}^b D_\theta^\gamma D_y^\mu F$ is continuous in all its variables
- (ii) φ_+, φ_- are of class H^{m+5} , and φ_+, φ_- satisfy the corner condition:
 $\varphi_+(0, y) = \varphi_-(0, y)$.
- (iii) There exists a real $T > 0$ such that F, φ_+, φ_- are T -periodic in each y_i .

then there exists a unique C^0 -solution φ for the problem (1.1) in one-sided future neighborhood $\cup \mathcal{V}_R$ of the initial data hypersurfaces N_+ and N_- .

Moreover, for all $l \geq 2$, if $m > \max(n - 1, \frac{n-1}{2} + 4 + l)$, and if for any $0 \leq a \leq l - 1$, $0 \leq b \leq l - 1$, $0 \leq \gamma + |\mu| \leq m + 1$, $D_t^a D_{x^1}^b D_\theta^\gamma D_y^\mu F$ is continuous in all its variables, then φ is in C^l .

Remark 7.1 : We have worked with the same periodicity T in each y_i , but we can proceed similarly with different periodicities in each y_i , the functions $\Psi_\alpha(v, y)$, and $\langle \Psi_\alpha, f \rangle$ will be a little more complicated, but we will get the same results.

Now we remove the assumption of periodicity in y . We can consider two cases: first $Y = \mathbb{R}^{n-1}$, then Y open set strictly included in \mathbb{R}^{n-1} . If \tilde{H} and $\tilde{\varphi}_-$ are defined on a set $Y = \mathbb{R}^{n-1}$ in their variable y (which is equivalent to F, φ_+, φ_- defined on $Y = \mathbb{R}^{n-1}$ in their variable y), we can work in a torus \mathbb{T}^{n-1} of length $2T$ in each y_i , multiply the functions F, φ_+, φ_- by a cut off function in y equal to 1 on the torus \mathbb{T}^{n-1} of length T in each y_i strictly included in \mathbb{T}^{n-1} , vanishing outside of \mathbb{T}^{n-1} . Then if we replace \mathbb{T}^{n-1} and T by $(\mathbb{T}')^{n-1}$ and T' (length of \mathbb{T}') in all the arguments, we get a solution on a one-sided future neighborhood Ω_T of N_+ and N_- , of length T in each y_i . We do it again with a torus \mathbb{T}''^{n-1} of length $4T$ in each y_i strictly including the torus \mathbb{T}^{n-1} , we get another solution on a neighborhood Ω_{2T} , but by the uniqueness it is the same on the intersection of both neighborhoods. So we have a solution on $\Omega_T \cup \Omega_{2T}$. By induction we construct a solution on $\cup_{k \in \mathbb{N}} \Omega_{2^k T}$.

Now if Y is an open set strictly included in \mathbb{R}^{n-1} , we can consider some torus $\mathbb{T}^{n-1} \subset \subset (\mathbb{T}')^{n-1} \subset Y$ (where $A \subset \subset B$ means $\bar{A} \subset B$). We multiply the functions \tilde{H} and $\tilde{\varphi}_-$ by a cut off function equal to 1 on \mathbb{T}^{n-1} and vanishing outside of $(\mathbb{T}')^{n-1}$ and we replace \mathbb{T}^{n-1} and T by $(\mathbb{T}')^{n-1}$ and T' (length of \mathbb{T}') in all the arguments, so we get a solution. We can't enlarge the torus as much as we want, but we can remark that when we consider again the intersection of the past light cone issued from $P(u, v, \tilde{y})$ (u as large as necessary) with N_+ , it's a part of parabola \mathcal{P} , which limit when $v \rightarrow 0$ is a segment $\{(s, 0, \tilde{y}); 0 \leq s \leq u\}$. This means that for any $u \geq 0$, we can find a $v \geq 0$ small enough such that the intersection of the past light cone issued of $P(u, v, \tilde{y})$ with the future of $N_+ \cup N_-$ is a set of points $Q(u', v', y')$ with y' in \mathbb{T}^{n-1} . So by eventually reducing the thickness of the neighborhood obtained in theorem 7.2, the well known uniqueness of a solution of a wave equation in the past light cone of a point assures that the solution obtained in our argument is the right one. Hence we will obtain a neighborhood of $N_+ \cup N_-$ which becomes thinner and thinner when we reach the boundary of each connex component of Y . So we finally get the following theorem:

Theorem 7.3 *If $m > \max(n - 1, \frac{n-1}{2} + 4)$, and*

(i) *The functions F, φ_+, φ_- are defined on \mathbb{R}^{n-1} in y .*

(ii) $F : (\theta, t, x^1, y) \mapsto F(\theta, t, x^1, y)$ satisfies that for any $0 \leq a \leq 1, 0 \leq b \leq 1, 0 \leq \gamma + |\mu| \leq m + 1$, $D_t^a D_{x^1}^b D_\theta^\gamma D_y^\mu F$ is continuous in all its variables

(iii) φ_+, φ_- are of class H^{m+5} , and φ_+, φ_- satisfy the corner condition:
 $\varphi_+(0, y) = \varphi_-(0, y)$.

then there exists a unique C^0 -solution φ for the problem (1.1) in one-sided future neighborhood of the initial data hypersurfaces N_+ and N_- .

Moreover, for all $l \geq 2$, if $m > \max(n - 1, \frac{n-1}{2} + 4 + l)$, and if for any $0 \leq a \leq l - 1, 0 \leq b \leq l - 1, 0 \leq \gamma + |\mu| \leq m + 1$, $D_t^a D_{x^1}^b D_\theta^\gamma D_y^\mu F$ is continuous in all its variables, then φ is in C^l .

8 Case \mathbb{R}^{1+1}

We consider the same problem as (1.1) with $n = 1$, namely

$$\begin{cases} \square\varphi(x, t) = F(\varphi(x, t), x, t) \\ \varphi|_{N_+} = \varphi_+ \\ \varphi|_{N_-} = \varphi_- \end{cases} \quad (8.1)$$

where $N_+ = \{t + x = 0, t \geq 0\}$

$N_- = \{t - x = 0, t \geq 0\}$

$$\square = -\frac{\partial^2}{\partial t^2} + \frac{\partial^2}{\partial x^2}.$$

We proceed similarly as we have done for the case \mathbb{R}^{n+1} . Indeed, we first change variable (t, x) to (u, v) , then we deal with a new equation in $\tilde{\varphi}$, and we approximate spectrally $\tilde{\varphi}$ by $\tilde{\varphi}_\varepsilon$. But in order to estimate $\|\tilde{\varphi}_\varepsilon(u)\|_{\mathcal{H}_{m,k}}$ we work with the norm $H^2([0, 2R]) = W^{2,2}([0, 2R])$. The estimations are similar but considerably simpler and we need weaker assumptions on the functions F, φ_+, φ_- . We obtain the following theorem.

Theorem 8.1 For all $l \geq 2$, if F is of class C^{l-1} , φ_+, φ_- are of class C^l , and φ_+, φ_- satisfy the corner condition:

$$\varphi_+(0, y) = \varphi_-(0, y),$$

then for all real $R > 0$, there exist some reals $R' > 0$ and $R'' > 0$ such that there exists a unique solution φ for the problem (8.1) in the domain $\Omega = \{0 \leq t - x \leq R, 0 \leq t + x \leq R'\} \cup \{0 \leq t + x \leq R, 0 \leq t - x \leq R''\}$ and this solution is in $C^l(\Omega)$.

A Appendix

A.1 Proof of $\mathcal{H}_{m,k}$ Hilbert space

We set for any f, g in $\mathcal{H}_{m,k}([0, 2R] \times \mathbb{T}^{n-1})$,

$$(f, g) = \sum_{\substack{0 \leq a \leq k \\ 0 \leq |\nu| \leq m}} \int_0^{2R} \int_{\mathbb{T}^{n-1}} (D_v^a D_y^\nu f)(D_v^a D_y^\nu g) dv d^{n-1}y.$$

(\cdot, \cdot) is a symmetric and positive definite real valued bilinear form. We show that $\mathcal{H}_{m,k}$ is complete for the associated norm $\|f\| = (f, f)^{\frac{1}{2}}$.

Indeed, let (u_n) be a Cauchy sequence in $\mathcal{H}_{m,k}([0, 2R] \times \mathbb{T}^{n-1})$, namely for all $0 \leq a \leq k$, for all $0 \leq |\nu| \leq m$, $(D_v^a D_y^\nu u_n)$ is a Cauchy sequence in $L^2([0; 2R] \times \mathbb{T}^{n-1})$. As $L^2([0; 2R] \times \mathbb{T}^{n-1})$ is a complete space, we know that for any $0 \leq a \leq k$, any $0 \leq |\nu| \leq m$, $(D_v^a D_y^\nu u_n)$ converges to a L^2 -function $g_{a\nu}$. It remains to state that $g_{a\nu} = D_v^a D_y^\nu u$. We recall that $(D_v^a D_y^\nu u_n)$ converges to $(D_v^a D_y^\nu u)$ in $\mathcal{D}'([0; 2R] \times \mathbb{T}^{n-1})$ (we denote by \mathcal{D}' the set of real-valued linear function defined on \mathcal{D} the set of smooth compact-supported functions). On another hand, for any ϕ in $\mathcal{D}([0; 2R] \times \mathbb{T}^{n-1})$, by the Cauchy-Schwarz inequality it is clear that

$$\left| \int_{[0; 2R] \times \mathbb{T}^{n-1}} (D_v^a D_y^\nu u_n - g_{a\nu}) \phi \right| \leq \|D_v^a D_y^\nu u_n - g_{a\nu}\|_{L^2([0; 2R] \times \mathbb{T}^{n-1})} \|\phi\|_{L^2([0; 2R] \times \mathbb{T}^{n-1})}.$$

So $(D_v^a D_y^\nu u_n)$ converges to $g_{a\nu}$ in $\mathcal{D}'([0; 2R] \times \mathbb{T}^{n-1})$. By the uniqueness of the limit in $\mathcal{D}'([0; 2R] \times \mathbb{T}^{n-1})$, we can say that $g_{a\nu} = D_v^a D_y^\nu u$. The sequence (u_n) converges to u in $\mathcal{H}_{m,k}$, so $\mathcal{H}_{m,k}$ is a complete space. \triangle

A.2 Proof of lemma 2.1

We keep the notations introduced in section "Spaces $\mathcal{H}_{m,k}$ ". Our goal here is to prove the equivalence of the $\mathcal{H}_{m,k}$ -norm defined above and the following one:

$$\|f\| = \left(\sum_{\alpha \in \mathbb{Z}^n} |\langle \psi_\alpha, f \rangle|^2 (1 + |\alpha_0|)^{2k} (1 + |\bar{\alpha}|)^{2m} \right)^{\frac{1}{2}}.$$

We first show that

$$\|f\|_{\mathcal{H}_{m,k}}^2 = \sum_{\substack{0 \leq a \leq k \\ 0 \leq j \leq m}} \left(\sum_{\alpha \in \mathbb{Z}^n} |\langle \psi_\alpha, f \rangle|^2 \left(\frac{\pi}{R}\right)^{2a} \left(\frac{2\pi}{T}\right)^{2j} |\alpha_0|^{2a} |\bar{\alpha}|^{2j} \right). \quad (\text{A.1})$$

(N.B.: in this paragraph, for more convenient we set by convention $0^0 = 1$, it avoids to distinguish the cases $a = 0, j = 0 \dots$)

It suffices for that to show that

$$\sum_{|\gamma|=j} \| D_v^a D_y^\gamma f \|_{L^2}^2 = \sum_{\alpha \in \mathbb{Z}^n} | \langle \psi_\alpha, f \rangle |^2 \left(\frac{\pi}{R} \right)^{2a} \left(\frac{2\pi}{T} \right)^{2j} |\alpha_0|^{2a} |\bar{\alpha}|^{2j}.$$

But we know that

$$f(v, y) = \sum_{\alpha \in \mathbb{Z}^n} \langle \psi_\alpha, f \rangle \psi_\alpha(v, y).$$

So by differentiating in v and y_i , we have for any l_1, \dots, l_j in $\{1, \dots, n-1\}$

$$D_v^a D_y^{l_1 \dots l_j} f(v, y) = \sum_{\alpha \in \mathbb{Z}^n} \langle \psi_\alpha, f \rangle \left(i \frac{\pi}{R} \right)^a \left(i \frac{2\pi}{T} \right)^j (\alpha_0)^a \alpha_{l_1} \dots \alpha_{l_j} \psi_\alpha(v, y).$$

Hence

$$\| D_v^a D_y^{l_1 \dots l_j} f(v, y) \|_{L^2}^2 = \sum_{\alpha \in \mathbb{Z}^n} | \langle \psi_\alpha, f \rangle |^2 \left(\frac{\pi}{R} \right)^{2a} \left(\frac{2\pi}{T} \right)^{2j} |(\alpha_0)^a \alpha_{l_1} \dots \alpha_{l_j}|^2.$$

Then we notice that

$$\begin{aligned} \sum_{l_1, \dots, l_j \in \{1, \dots, n-1\}} |\alpha_0|^{2a} |\alpha_{l_1}|^2 \dots |\alpha_{l_j}|^2 &= |\alpha_0|^{2a} \sum_{l_1, \dots, l_j \in \{1, \dots, n-1\}} |\alpha_{l_1}|^2 \dots |\alpha_{l_j}|^2 \\ &= |\alpha_0|^{2a} (|\alpha_1|^2 + \dots + |\alpha_{n-1}|^2)^j \\ &= |\alpha_0|^{2a} |\bar{\alpha}|^{2j}. \end{aligned}$$

Thus we get (A.1).

Now to obtain the equivalence of the norms it remains to find two constants K and K' such that

$$K(1 + |\alpha_0|)^{2k} (1 + |\bar{\alpha}|)^{2m} \leq \sum_{\substack{0 \leq a \leq k \\ 0 \leq j \leq m}} \left(\frac{\pi}{R} \right)^{2a} \left(\frac{2\pi}{T} \right)^{2j} |\alpha_0|^{2a} |\bar{\alpha}|^{2j} \leq K'(1 + |\alpha_0|)^{2k} (1 + |\bar{\alpha}|)^{2m}.$$

Let $K' = \max(1, \left(\frac{\pi}{R}\right)^2, \left(\frac{\pi}{R}\right)^{2k}, \left(\frac{2\pi}{T}\right)^2, \left(\frac{2\pi}{T}\right)^{2m}, \left(\frac{\pi}{R}\right)^2 \left(\frac{2\pi}{T}\right)^2, \left(\frac{\pi}{R}\right)^2 \left(\frac{2\pi}{T}\right)^{2m}, \left(\frac{\pi}{R}\right)^{2k} \left(\frac{2\pi}{T}\right)^2, \left(\frac{\pi}{R}\right)^{2k} \left(\frac{2\pi}{T}\right)^{2m})$.
Therefore

$$\begin{aligned} 1 + \left(\frac{\pi}{R}\right)^2 |\alpha_0|^2 + \dots + \left(\frac{\pi}{R}\right)^{2k} \left(\frac{2\pi}{T}\right)^{2m} |\alpha_0|^{2k} |\bar{\alpha}|^{2m} &\leq K'(1 + |\alpha_0|^2 + \dots + |\alpha_0|^{2k} |\bar{\alpha}|^{2m}) \\ &\leq K' \sum_{l=0}^{2k} C_{2k}^l |\alpha_0|^l \sum_{h=0}^{2m} C_{2m}^h |\bar{\alpha}|^h \\ &\leq K'(1 + |\alpha_0|)^{2k} (1 + |\bar{\alpha}|)^{2m}. \end{aligned}$$

Thus we can write

$$\|f\|_{\mathcal{H}_{m,k}}^2 \leq K' \sum_{\alpha \in \mathbb{Z}^n} |\langle \psi_\alpha, f \rangle|^2 (1 + |\alpha_0|)^{2k} (1 + |\bar{\alpha}|)^{2m}.$$

We denote

$$\tilde{K} = \min(1, (\frac{\pi}{R})^2, (\frac{\pi}{R})^{2k}, (\frac{2\pi}{T})^2, (\frac{2\pi}{T})^{2m}, (\frac{\pi}{R})^2 (\frac{2\pi}{T})^2, (\frac{\pi}{R})^2 (\frac{2\pi}{T})^{2m}, (\frac{\pi}{R})^{2k} (\frac{2\pi}{T})^2, (\frac{\pi}{R})^{2k} (\frac{2\pi}{T})^{2m}).$$

So

$$\tilde{K}(1 + |\alpha_0|^2 + \dots + |\alpha_0|^{2k} |\bar{\alpha}|^{2m}) \leq 1 + (\frac{\pi}{R})^2 |\alpha_0|^2 + \dots + (\frac{\pi}{R})^{2k} (\frac{2\pi}{T})^{2m} |\alpha_0|^{2k} |\bar{\alpha}|^{2m}$$

By induction, we can calculate c_i such that

$$\begin{aligned} c_k(1 + |\alpha_0|)^{2k} &\leq 1 + |\alpha_0|^2 + \dots + |\alpha_0|^{2k} \\ c_m(1 + |\bar{\alpha}|)^{2m} &\leq 1 + |\bar{\alpha}|^2 + \dots + |\bar{\alpha}|^{2m} \end{aligned}$$

(take $c_1 = \frac{1}{2}, c_{i+1} = \frac{c_i}{4}$). Furthermore,

$$\begin{aligned} c_k(1 + |\alpha_0|)^{2k} (1 + |\bar{\alpha}|^2 + \dots + |\bar{\alpha}|^{2m}) &\leq (1 + |\alpha_0|^2 + \dots + |\alpha_0|^{2k} |\bar{\alpha}|^{2m}) \\ c_k(1 + |\alpha_0|)^{2k} c_m(1 + |\bar{\alpha}|)^{2m} &\leq (1 + |\alpha_0|^2 + \dots + |\alpha_0|^{2k} |\bar{\alpha}|^{2m}). \end{aligned}$$

We deduce from this that,

$$\tilde{K} c_k c_m \sum_{\alpha \in \mathbb{Z}^n} |\langle \psi_\alpha, f \rangle|^2 (1 + |\alpha_0|)^{2k} (1 + |\bar{\alpha}|)^{2m} \leq \|f\|_{\mathcal{H}_{m,k}}^2.$$

Remark A.1 : As it is done in the classical Sobolev spaces, we extend the spaces $\mathcal{H}_{m,k}$ to m, k positive reals by the definition below:

$$\mathcal{H}_{m,k}([0; 2R] \times \mathbb{T}^{n-1}) = \{f \in L^2([0; 2R] \times \mathbb{T}^{n-1}); \sum_{\alpha \in \mathbb{Z}^n} |\langle \psi_\alpha, f \rangle|^2 (1 + |\alpha_0|)^{2k} (1 + |\bar{\alpha}|)^{2m} < \infty\}$$

△

A.3 Proof of lemma 2.2

We begin by establishing the following embedding .

$$\text{If } \begin{cases} m > \frac{n-1}{2} \\ k > \frac{1}{2} \end{cases} \text{ then } \mathcal{H}_{m,k}([0; 2R] \times \mathbb{T}^{n-1}) \subset L^\infty([0; 2R] \times \mathbb{T}^{n-1}).$$

We recall that

$$f = \sum_{\alpha \in \mathbb{Z}^n} f_\alpha (2R)^{-\frac{1}{2}} T^{-\frac{n-1}{2}} e^{i(\alpha_0 v \frac{\pi}{R} + \bar{\alpha} \cdot y \frac{2\pi}{T})}$$

where $f_\alpha = \langle \Psi_\alpha, f \rangle$. Therefore

$$\|f\|_{L^\infty} \leq (2R)^{-\frac{1}{2}} T^{-\frac{n-1}{2}} \sum_{\alpha \in \mathbb{Z}^n} |f_\alpha|$$

By the Cauchy-Schwarz inequality, we get

$$\begin{aligned} \sum_{\alpha \in \mathbb{Z}^n} |f_\alpha| &= \sum_{\alpha \in \mathbb{Z}^n} (|f_\alpha| (1 + |\alpha_0|)^k (1 + |\bar{\alpha}|)^m) \times \frac{1}{(1 + |\alpha_0|)^k (1 + |\bar{\alpha}|)^m} \\ &\leq \|f\| \left(\sum_{\alpha \in \mathbb{Z}^n} \frac{1}{(1 + |\alpha_0|)^{2k} (1 + |\bar{\alpha}|)^{2m}} \right)^{\frac{1}{2}}. \end{aligned}$$

But we know that

$$\begin{aligned} \sum_{\alpha \in \mathbb{Z}^n} \frac{1}{(1 + |\alpha_0|)^{2k} (1 + |\bar{\alpha}|)^{2m}} &= \int_{x \in \mathbb{R}} \int_{y \in \mathbb{R}^{n-1}} \frac{1}{(1 + |x|)^{2k} (1 + |y|)^{2m}} dx d^{n-1}y \\ &= \int_{x \in \mathbb{R}} \frac{1}{(1 + |x|)^{2k}} dx \int_{y \in \mathbb{R}^{n-1}} \frac{1}{(1 + |y|)^{2m}} d^{n-1}y. \end{aligned}$$

These both integrals are convergent if $2k > 1$ and $2m > n - 1$ i.e. $k > \frac{1}{2}$ and $m > \frac{n-1}{2}$. At last, by using the equivalence of the norms above, we obtain

$$\|f\|_{L^\infty} \leq c \|f\|_{\mathcal{H}_{m,k}}.$$

Now we show that
if $\begin{cases} m > \frac{n-1}{2} \\ k > \frac{1}{2} \end{cases}$ then $\mathcal{H}_{m,k}([0; 2R] \times \mathbb{T}^{n-1}) \subset C^0([0; 2R] \times \mathbb{T}^{n-1})$.

Let f in $\mathcal{H}_{m,k}$, for every n in \mathbb{N}^* , we set $f_n = \hat{J}_{\frac{1}{n}} f$ (\hat{J} has been defined in section "Spectral approximation of $\tilde{\varphi}$ "). It is clear that f_n are in $\mathcal{H}_{m,k}$, and that

$$\|f_n\|_{L^\infty} \leq c \|f_n\|_{\mathcal{H}_{m,k}}. \quad (\text{A.2})$$

Then by the theorem of Plancherel we have $\|\hat{J}_{\frac{1}{n}} v - v\|_{L^2} \rightarrow 0$, if we apply this to $v = f, \dots, D_v^k D_y^m f$, we get

$$\|f - f_n\|_{\mathcal{H}_{m,k}} \rightarrow 0.$$

The sequence (f_n) converges to f in $\mathcal{H}_{m,k}$, hence (f_n) is a Cauchy sequence in $\mathcal{H}_{m,k}$, and in L^∞ by (A.2). Moreover the functions f_n are continuous, so (f_n) is a Cauchy sequence in $C^0([0; 2R] \times \mathbb{T}^{n-1})$. As this space is complete it implies that (f_n) converges to g in $C^0([0; 2R] \times \mathbb{T}^{n-1})$.

It remains to show that $f = g$ almost everywhere. (f_n) converges to g in L^2 , indeed

$$\|f_n - g\|_{L^2([0; 2R] \times \mathbb{T}^{n-1})} \leq (2R \times T^{n-1})^{\frac{1}{2}} \|f_n - g\|_{L^\infty([0; 2R] \times \mathbb{T}^{n-1})} \rightarrow 0.$$

But (f_n) converges to f in $\mathcal{H}_{m,k}$, in particular (f_n) converges to f in L^2 , by the uniqueness of the limit in L^2 , we can write that $f = g$ almost everywhere.

For the class C^l , it suffices to apply the result above to $\frac{\partial}{\partial v} f, \frac{\partial}{\partial y_i} f, \dots, D_v^l D_y^l f$. △

A.4 Proof of lemma 2.3

We want to show that if $k < k'$ then the embedding $\mathcal{H}_{m,k'} \hookrightarrow \mathcal{H}_{m,k}$ is compact. We deal with the equivalent norm $\|f\|$ defined above and we will denote it also $\|f\|_{\mathcal{H}_{m,k}}$. As $(1 + \alpha_0)^{2k} \leq (1 + \alpha_0)^{2k'}$ it is clear that $\|\dots\|_{\mathcal{H}_{m,k}} \leq \|\dots\|_{\mathcal{H}_{m,k'}}$. Set $i : \mathcal{H}_{m,k'} \hookrightarrow \mathcal{H}_{m,k}$, i is a compact operator if it changes a bounded set in a relatively compact set. Let (f_n) a bounded sequence of $\mathcal{H}_{m,k'}$. We have seen that $\mathcal{H}_{m,k'}$ is reflexive so we can extract a subsequence $(f_{n'})$ of (f_n) which weakly converges to f in $\mathcal{H}_{m,k'}$, and $\|f\|_{\mathcal{H}_{m,k'}} \leq \liminf \|f_{n'}\|_{\mathcal{H}_{m,k'}} \leq M$. We consider $\|f_{n'} - f\|_{\mathcal{H}_{m,k}}^2$ and cut the sum on $\alpha \in \mathbb{Z}^n$ in two parts, namely I and II , as it follows

$$\|f_{n'} - f\|_{\mathcal{H}_{m,k}}^2 = I + II$$

with

$$\begin{aligned} I &= \sum_{|\alpha| \leq A} |\langle \psi_\alpha, f_{n'} - f \rangle|^2 (1 + |\alpha_0|)^{2k} (1 + |\bar{\alpha}|)^{2m} \\ II &= \sum_{|\alpha| > A} |\langle \psi_\alpha, f_{n'} - f \rangle|^2 \frac{(1 + |\alpha_0|)^{2k'}}{(1 + |\alpha_0|)^{2(k'-k)}} (1 + |\bar{\alpha}|)^{2m} \end{aligned}$$

The function $f \mapsto \langle \psi_\alpha, f \rangle$ is a continuous linear form on $\mathcal{H}_{m,k'}$, hence $\langle \psi_\alpha, f_{n'} \rangle \rightarrow \langle \psi_\alpha, f \rangle$ i.e. $\langle \psi_\alpha, f_{n'} - f \rangle \rightarrow 0$. It implies that for all $\varepsilon_1 > 0$ there exists $\eta > 0$ such that for all $n' > \eta$, $\sum_{|\alpha| \leq A} |\langle \psi_\alpha, f_{n'} - f \rangle|^2 < \varepsilon_1^2$. So

$$I \leq \varepsilon_1^2 (1 + A)^{2k+2m}.$$

We treat now the second term II . We notice that

$$\begin{aligned} II &\leq \frac{1}{(1 + A)^{2(k'-k)}} \|f_{n'} - f\|_{\mathcal{H}_{m,k'}}^2 \\ &\leq \frac{1}{(1 + A)^{2(k'-k)}} (\|f_{n'}\|_{\mathcal{H}_{m,k'}} + \|f\|_{\mathcal{H}_{m,k'}})^2 \\ &\leq \frac{4M^2}{(1 + A)^{2(k'-k)}}. \end{aligned}$$

Therefore for all $\varepsilon > 0$, we choose A tall enough to get $\frac{4M^2}{(1+A)^{2(k'-k)}} \leq \frac{\varepsilon^2}{2}$. Then we set $\varepsilon_1 = \frac{\varepsilon}{\sqrt{2(1+A)^{2k+2m}}}$. So there exists η in \mathbb{N} such that for all $n' \geq \eta$,

$$\begin{aligned} \|f_{n'} - f\|_{\mathcal{H}_{m,k}}^2 &\leq \varepsilon_1^2 (1 + A)^{2k+2m} + \frac{4M^2}{(1 + A)^{2(k'-k)}} \\ &\leq \frac{\varepsilon^2}{2} + \frac{\varepsilon^2}{2} = \varepsilon^2. \end{aligned}$$

We obtain that $(f_{n'})$ converges to f in $\mathcal{H}_{m,k}$. It means that $i(f_n)$ is a compact set *a fortiori* a relatively compact set.

We proceed similarly for the compact embedding $\mathcal{H}_{m',k} \hookrightarrow \mathcal{H}_{m,k}$ if $m < m'$.

A.5 Proof of lemma 2.4

Here we suppose that $f \in \mathcal{H}_{m,k} \cap \mathcal{H}_{m,k'}$ with $k < k'$, Let $\gamma \in [0; 1]$, it is clear that $\mathcal{H}_{m,k'} \subset \mathcal{H}_{m,\gamma k+(1-\gamma)k'}$, so f is in $\mathcal{H}_{m,\gamma k+(1-\gamma)k'}$. We know that

$$\|f\|_{\mathcal{H}_{m,\gamma k+(1-\gamma)k'}}^2 = \sum_{\alpha \in \mathbb{Z}^n} |\langle \psi_\alpha, f \rangle|^2 (1 + |\alpha_0|)^{2\gamma k+(1-\gamma)k'} (1 + |\bar{\alpha}|)^{2m}.$$

If we set

$$\begin{aligned} g(\alpha) &= (|\langle \psi_\alpha, f \rangle|^2 (1 + |\alpha_0|)^{2k} (1 + |\bar{\alpha}|)^{2m})^\gamma \\ h(\alpha) &= (|\langle \psi_\alpha, f \rangle|^2 (1 + |\alpha_0|)^{2k'} (1 + |\bar{\alpha}|)^{2m})^{1-\gamma} \end{aligned}$$

we can write that

$$\|f\|_{\mathcal{H}_{m,\gamma k+(1-\gamma)k'}}^2 = \sum_{\alpha \in \mathbb{Z}^n} g(\alpha)h(\alpha).$$

Then by using Hölder inequality, we get

$$\sum_{\alpha \in \mathbb{Z}^n} g(\alpha)h(\alpha) \leq \left(\sum_{\alpha \in \mathbb{Z}^n} |g(\alpha)|^{\frac{1}{\gamma}} \right)^\gamma \left(\sum_{\alpha \in \mathbb{Z}^n} |h(\alpha)|^{\frac{1}{1-\gamma}} \right)^{1-\gamma}.$$

As

$$\begin{aligned} \left(\sum_{\alpha \in \mathbb{Z}^n} |\langle \psi_\alpha, f \rangle|^2 (1 + |\alpha_0|)^{2k} (1 + |\bar{\alpha}|)^{2m} \right)^\gamma &= \|f\|_{\mathcal{H}_{m,k}}^{2\gamma} \\ \left(\sum_{\alpha \in \mathbb{Z}^n} |\langle \psi_\alpha, f \rangle|^2 (1 + |\alpha_0|)^{2k'} (1 + |\bar{\alpha}|)^{2m} \right)^{1-\gamma} &= \|f\|_{\mathcal{H}_{m,k'}}^{2(1-\gamma)} \end{aligned}$$

we finally obtain,

$$\|f\|_{\mathcal{H}_{m,\gamma k+(1-\gamma)k'}}^2 \leq \|f\|_{\mathcal{H}_{m,k}}^{2\gamma} \|f\|_{\mathcal{H}_{m,k'}}^{2(1-\gamma)}.$$

We proceed similarly for the case $f \in \mathcal{H}_{m,k} \cap \mathcal{H}_{m',k}$ with $m < m'$, hence we can say that for all γ in $[0; 1]$,

$$f \text{ is in } \mathcal{H}_{\gamma m+(1-\gamma)m',k} \text{ and } \|f\|_{\mathcal{H}_{\gamma m+(1-\gamma)m',k}} \leq \|f\|_{\mathcal{H}_{m,k}}^\gamma \|f\|_{\mathcal{H}_{m',k}}^{1-\gamma}. \quad \triangle$$

B Appendix

B.1 Proof of the lemma 6.2

We notice that

$$\begin{aligned}
& \left\| \int_0^v f(s, y) ds \right\|_{\mathcal{H}_{m',1}([0;R] \times \mathbb{T}^{n-1})} \\
&= \sum_{\substack{0 \leq a \leq k \\ 0 \leq |\nu| \leq m'}} \left\| \frac{\partial^a}{\partial v^a} D_y^\nu \int_0^v f(s, y) ds \right\|_{L^2([0;R] \times \mathbb{T}^{n-1})} \\
&= \sum_{0 \leq |\nu| \leq m'} \left\| D_y^\nu \int_0^v f(s, y) ds \right\|_{L^2([0;R] \times \mathbb{T}^{n-1})} + \sum_{0 \leq |\nu| \leq m'} \left\| D_y^\nu f(v, y) \right\|_{L^2([0;R] \times \mathbb{T}^{n-1})}.
\end{aligned}$$

If $D_y^\nu f$ is in $C^0([0;R] \times \mathbb{T}^{n-1})$ then

$$D_y^\nu \int_0^v f(s, y) ds = \int_0^v D_y^\nu f(s, y) ds$$

and by the inequality of Cauchy-Schwarz

$$\left| \int_0^v D_y^\nu f(s, y) ds \right| \leq v^{\frac{1}{2}} \left\| D_y^\nu f(v, y) \right\|_{L^2([0;v])} \leq R^{\frac{1}{2}} \left\| D_y^\nu f(v, y) \right\|_{L^2([0;R])}.$$

Thus

$$\begin{aligned}
\left\| D_y^\nu \int_0^v f(s, y) ds \right\|_{L^2}^2 &= \int_0^R \int_{\mathbb{T}^{n-1}} \left| D_y^\nu \int_0^v f(s, y) ds \right|^2 dv d^{n-1}y \\
&\leq R^{\frac{3}{2}} \int_{\mathbb{T}^{n-1}} \int_0^R \left| D_y^\nu f(v, y) \right|^2 dv d^{n-1}y \\
&= R^{\frac{3}{2}} \left\| D_y^\nu f(v, y) \right\|_{L^2([0;R] \times \mathbb{T}^{n-1})}^2.
\end{aligned}$$

Finally we obtain

$$\left\| \int_0^v f(s, y) ds \right\|_{\mathcal{H}_{m',1}([0;R] \times \mathbb{T}^{n-1})} \leq (R^{\frac{3}{2}} + 1) \left\| f(s, y) \right\|_{\mathcal{H}_{m',0}([0;R] \times \mathbb{T}^{n-1})}.$$

△

B.2 Proof of the lemma 6.3

By definition

$$\left\| \int_u^{u+h} f(\sigma) d\sigma \right\|_{\mathcal{H}_{\mu,1}} = \sum_{\substack{0 \leq a \leq 1 \\ 0 \leq |\nu| \leq \mu}} \left\| \frac{\partial^a}{\partial v^a} D_y^\nu \int_u^{u+h} f(\sigma) d\sigma \right\|_{L^2}$$

And if $D_v^a D_y^\nu f$ is continuous in all its variables, we have

$$\begin{aligned}
\| D_v^a D_y^\nu \int_u^{u+h} f(\sigma) d\sigma \|_{L^2}^2 &= \| \int_u^{u+h} D_v^a D_y^\nu f(\sigma) d\sigma \|_{L^2}^2 \\
&= \int_0^R \int_{\mathbb{T}^{n-1}} \left| \int_u^{u+h} D_v^a D_y^\nu f(\sigma) d\sigma \right|^2 dv d^{n-1}y \\
&= \int_0^R \int_{\mathbb{T}^{n-1}} \left(\int_u^{u+h} D_v^a D_y^\nu f(\sigma) d\sigma \right) \left(\int_u^{u+h} D_v^a D_y^\nu f(\gamma) d\gamma \right) dv d^{n-1}y.
\end{aligned}$$

We can commute the integration in σ and (v, y) by using the theorem of Fubini, hence

$$\| \int_u^{u+h} D_v^a D_y^\nu f(\sigma) d\sigma \|_{L^2}^2 = \int_u^{u+h} \left(\int_0^R \int_{\mathbb{T}^{n-1}} D_v^a D_y^\nu f(\sigma) \left(\int_u^{u+h} D_v^a D_y^\nu f(\gamma) d\gamma \right) dv d^{n-1}y \right) d\sigma.$$

Then by the inequality of Cauchy-Schwarz used on the integration in (v, y) , we get

$$\begin{aligned}
&\| \int_u^{u+h} D_v^a D_y^\nu f(\sigma) d\sigma \|_{L^2([0;R] \times \mathbb{T}^{n-1})}^2 \\
&\leq \int_u^{u+h} \left(\| D_v^a D_y^\nu f(\sigma) \|_{L^2([0;R] \times \mathbb{T}^{n-1})} \right) \left\| \int_u^{u+h} D_v^a D_y^\nu f(\gamma) d\gamma \right\|_{L^2([0;R] \times \mathbb{T}^{n-1})} d\sigma.
\end{aligned}$$

The second factor under the integral in σ is independent of σ , so we can get it out, thus

$$\begin{aligned}
&\| \int_u^{u+h} D_v^a D_y^\nu f(\sigma) d\sigma \|_{L^2([0;R] \times \mathbb{T}^{n-1})}^2 \\
&\leq \left\| \int_u^{u+h} D_v^a D_y^\nu f(\gamma) d\gamma \right\|_{L^2([0;R] \times \mathbb{T}^{n-1})} \int_u^{u+h} \left(\| D_v^a D_y^\nu f(\sigma) \|_{L^2([0;R] \times \mathbb{T}^{n-1})} \right) d\sigma.
\end{aligned}$$

Then if $\left\| \int_u^{u+h} D_v^a D_y^\nu f(\sigma) d\sigma \right\|_{L^2([0;R] \times \mathbb{T}^{n-1})}$ vanishes, the inequality we want to show is trivial. Else we can divide by this positive quantity and so obtain

$$\| D_v^a D_y^\nu \int_u^{u+h} f(\sigma) d\sigma \|_{L^2([0;R] \times \mathbb{T}^{n-1})} \leq \int_u^{u+h} \left(\| D_v^a D_y^\nu f(\sigma) \|_{L^2([0;R] \times \mathbb{T}^{n-1})} \right) d\sigma.$$

To conclude it suffices to add this inequality on every $0 \leq a \leq 1$, $0 \leq |\nu| \leq \mu$. △

References

- [1] Francis Cagnac. Problème de Cauchy sur un conoïde caractéristique. *Ann. Fac. Sci. Toulouse Math.* (5), 2(1):11–19, 1980.

- [2] Francis Cagnac and Marcel Dossa. Problème de Cauchy sur un cône caractéristique. Applications à certains systèmes non linéaires d'origine physique. In *Physics on manifolds (Paris, 1992)*, volume 15 of *Math. Phys. Stud.*, pages 35–47. Kluwer Acad. Publ., Dordrecht, 1994.
- [3] R. Courant and D. Hilbert. *Methods of mathematical physics. Vol. II: Partial differential equations.* (Vol. II by R. Courant.). Interscience Publishers (a division of John Wiley & Sons), New York-London, 1962.
- [4] H. Friedrich. On the regular and the asymptotic characteristic initial value problem for Einstein's vacuum field equations. *Proc. Roy. Soc. London Ser. A*, 375(1761):169–184, 1981.
- [5] Henning Müller zum Hagen and Hans-Jürgen Seifert. On characteristic initial-value and mixed problems. *General Relativity and Gravitation*, 8(4):259–301, 1977.
- [6] A. D. Rendall. Reduction of the characteristic initial value problem to the Cauchy problem and its applications to the Einstein equations. *Proc. Roy. Soc. London Ser. A*, 427(1872):221–239, 1990.
- [7] Michael E. Taylor. *Partial differential equations. III*, volume 117 of *Applied Mathematical Sciences*. Springer-Verlag, New York, 1997. Nonlinear equations, Corrected reprint of the 1996 original.